



**PROGRAMME ARRANGEMENT**  
and  
**IMPLEMENTATION DOCUMENT**  
**NATIONAL BIODIGESTER PROGRAMME**  
in **CAMBODIA**



**Phnom Penh, Cambodia**  
**January, 2006**

## **PROGRAMME ARRANGEMENT**

**between the Ministry of Agriculture, Forestry and Fisheries (MAFF) and SNV Netherlands Development Organization for the implementation of a National Biodigester Programme in the Kingdom of Cambodia.**

### **1. GENERAL**

This Programme Arrangement is a further elaboration of a MoU signed between the Ministry of Agriculture, Forestry and Fisheries (MAFF) and SNV Netherlands Development Organization on May 24, 2005 and expresses further the understanding of both parties to have the National Biodigester Programme implemented. A Biodigester Programme Office (BPO), established within the Department of Animal Health and Production (DAHP), will have the responsibility for planning, coordination and monitoring of the programme. Implementing agencies on provincial level are:

- the Department of Agriculture of Kampong Cham;
- the Department of Agriculture of Svay Rieng;
- the Department of Agriculture of Prey Veng;
- the Department of Agriculture of Kandal;
- the Department of Agriculture of Takeo, and;
- the Department of Agriculture of Kampong Speu.

The implementation arrangements are detailed in the Programme Implementation Document, included as annex to this arrangement.

### **2. EXECUTING AUTHORITIES**

The executing authorities for this programme will be:

- Ministry of Agriculture, Forestry and Fisheries (MAFF). MAFF nominates the DAHP as the advisory and coordinating agency for the programme.
  
- SNV Netherlands Development Organization. SNV assists in the setting-up and functioning of the Biodigester Programme Office (BPO) by supplying advisory services.

### **3. PROGRAMME DESCRIPTION**

The programme description is detailed in the Programme Implementation Document attached to this arrangement.

### **4. IMPLEMENTATION GUIDELINES**

The BPO will make separate agreements with the implementing agencies on the implementation guidelines. These guidelines will include, besides field activities like promotion quality control and extension, the financial and reporting arrangements.

### **5. FACILITATION**

The DAHP and implementing agencies will provide personnel and facilities necessary to enable the programme to efficiently and economically carry out programme activities. Such contribution will include:



## EXECUTIVE SUMMARY

Cambodia, situated in the south-western part of the Indochina peninsula, covers a total land area of some 181,035 square kilometres. It is home to about 13.6 million people (2005) with over 38 per cent of the entire population is under the age of 15 and 29 per cent in the age group 12-22. The average household size in rural Cambodia is 5.4 people. Some 75% of the population depends on subsistence farming as their main source of income. Farming is mostly based in an integrated system combining crop production and animal husbandry. Livestock consist mostly of cattle and pigs. Cattle are kept for beef, draft power and as safekeeping of financial resources. Pigs are kept for meat and as a source of financial income. Small farms are the norm, between 0.8 and 2 hectares, and almost all farmers are engaged in rice cultivation. The average rice crop yield is with 1.3 tons/ha low compared to the neighbouring countries. The Gross National Product (GNP) per capita in 2002 amounted to US\$ 2060.

Energy sources in Cambodia can be broadly classified into three groups: traditional (biomass), commercial (non-biomass) and renewable energy. Traditional energy includes fuelwood, agricultural residues and charcoal. Commercial energy comprises electricity and petroleum products, the latter is entirely imported. Hydropower, biogas and solar are termed as renewable sources of energy.

The energy consumption in Cambodia amounted in 1995 to about 95,000 Tera-Joule of which 85% was covered by biomass. In the rural areas more than 90% of the energy consumption is biomass based. Especially in the southern provinces fuelwood demand has surpassed the production and consumers have become dependent on traded fuelwood from rubber plantations and from the more forested northern provinces. At a conservative price of US\$ 0.04 per kg at the village markets and a consumption of more than 9 kg/day, the cost of fuel is a substantial daily burden for the average rural household. Kerosene and electricity are mainly used for lighting; LPG is used for cooking but only in the urban areas. In rural areas traditional energy sources will remain the main supplier of energy in the foreseeable future. Biogas produced from cattle and pig manure may be one of the most appropriate alternate sources with an estimated technical potential of 224,000 household biodigesters in 6 southern provinces.

Domestic biodigesters have a large number of benefits. In most cases it replaces fuelwood as the principle source of energy for cooking in rural households where the technology has been introduced. This saves women time in cooking and in cleaning cooking utensils. It also reduces the financial burden of buying fuelwood and/or reduces the time spend on collecting fuelwood. Cooking with biogas instead of fuelwood significantly reduces the amount of smoke and unhealthy particles emitted from wood fire which, in turn, has a beneficial effect on the health status of the persons concerned, especially women and children.

The use of biodigesters reduces the consumption of fuelwood and has thus a positive effect on the rate of deforestation. With the proper application of the digesters effluent, it helps to reduce the loss of nutrients where now (pig) manure is discarded onto surface water and/or where nutrients are allowed to leach into the soil. The hygienic conditions around the farm improve because of a better manure management resulting in lesser smell from pig dung storage ponds and by the attachment of latrines to the digesters.

After a first contact between a Cambodian Government delegation and SNV during the Conference for Renewable energy in Bonn in June 2004, a feasibility study was conducted on the setting up of a national biodigester programme in Cambodia. The main recommendation of this study was to establish a National Biodigester Programme to come to the commercial and structural deployment of biodigester technology. As the most appropriate ministry to host such a programme, with direct linkage to the target population and with the most extensive infrastructure, the Ministry of Agriculture, Forestry and Fisheries (MAFF) was identified.

Based on the findings and recommendations of the feasibility study, a National Biodigester Programme in Cambodia was included in the Asia Biogas Programme Proposal. This proposal aims at providing access to biogas to 1,300,000 million people in Asia over the period 2005 – 2011 and an agreement between DGIS and SNV was reached in December 2004 on the co-financing of the proposal.

In May 2005 MAFF and SNV signed a MoU on cooperation in a national biodigester programme and since July 2005 a SNV biogas advisor is assisting MAFF in the preparations for the implementation of such a programme.

The overall objective of the first phase of the National Biodigester Programme is the dissemination of domestic biodigesters as an indigenous, sustainable energy source through the development of a commercial, market oriented, biodigester sector in selected provinces of Cambodia.

The specific objectives of the first phase of the National Biodigester Programme contributing to its overall objective are:

- To increase the number of family sized, quality biodigesters with 17,500 in selected provinces;
- To ensure the continued operation of all biodigesters installed under the biodigester programme;
- To maximise the benefits of the operated biodigesters, in particular the optimum use of digester effluent;
- Technical and promotional capacity development for further wide scale deployment of biodigester technology in Cambodia;
- To strengthen and facilitate establishment of institutions for the continued and sustained development of the biodigester sector.

The programme requires efforts in the fields of promotion and marketing, construction, repair and maintenance, quality control, lending, R&D, training, extension, monitoring and evaluation.

Promotion and marketing is a task to be undertaken by building contractors and mason teams. However, also the provincial programme offices, (INGO's and line agencies will play their part. The National Biodigester Programme office will undertake supporting activities like the development and production of posters and brochures and the broadcasting of messages in national media.

Construction, annual maintenance and repair will be done by registered commercial companies or, if such companies do not yet exist, by mason teams. These teams will only be allowed to operate after the successful completion of a technical training and under strict

supervision of the provincial biodigester programme office. In the long run the mason teams have to be developed in registered companies.

Financing of the construction of biodigesters comprises out of a subsidy part and a farmers contribution. Besides lowering the financial threshold for farmers who have the technical potential but little financial means the subsidy serves as an important promotion tool and provides a tool to safeguard quality standards on plant construction and after sales service.

An investment subsidy of US\$ 100 is considered sufficient to attract potential farmers while not being significantly excessive as to result in relative high FIRR for the farmers. By providing a fixed sum subsidy for all plant sizes the smaller farmers get percentage wise a higher subsidy on their investment while the administration is simplified. The farmer's contribution has to come from their own financial reserves and/or from bank loans. The main rural bank, ACLEDA, and the micro finance institute TPC have agreed to provide loans for biodigester construction to farmers at the same conditions they are using for other small commercial loans, approximately 3% interest per month and a 2 year repayment period. The financial institutions will also be used to channel the subsidy funds to the farmers.

The quality of goods and services, pre-construction information, construction, user training and extension, provided to the clients are key to the success of the programme. Recognition of biodigester companies and mason groups is subject to strict conditions to be laid down in an agreement. Quality of construction and after sales service will be checked randomly and if not found as agreed upon, corrective measures will be taken. Quality of operation and maintenance will be closely monitored as well. Extension through masons and supervisors will be combined with female user's group trainings and (I)NGO involvement.

Applied R&D will focus on development and testing of plant and appliances modifications in order to reduce cost and improve reliability and user friendliness. It comprises also activities to solve emerging technical problems of the present design. Special attention will be given to the most effective digester effluent use and extension. Studies to assess the exact impact of a large scale introduction of biodigesters will be conducted.

As the introduction of fixed dome biodigesters is relatively new to Cambodia, training of all parties involved in the programme will be essential. This includes training of companies, mason teams and provincial programme office staff in construction, maintenance, quality control, management, marketing, etc. Bank and (I)NGO staff will be trained in promotion and extension, female users on operation and maintenance.

The main focus of extension will be on an optimal use of biodigester effluent. A special section for this purpose will be established within the national programme office to determine the possible uses of the effluent in the Cambodian context and how to best reach the farmers with this message. The experiences with effluent use in countries within the region with running biodigester programmes will be taken into account and close cooperation with line agencies and agricultural projects will be sought on this topic.

In addition to more technical R&D, monitoring and evaluation will take place to study the effects of promotion, training and extension activities. The key question here will be how to transform potential demand into active demand.

The programme, although limited in duration, has the larger aim of building institutions needed for the continued and sustained viability of the sector beyond the duration of the programme itself. Capacity building within existing institutions is therefore an activity of the programme. This implies that as much as possible the above mentioned activities will be conducted by national and provincial governmental organisations, private sector and (I)NGO's.

Benefits deriving from the implementation of the proposed programme would be considerable. They include:

- significantly reduction of the workload of 16,625 households (5% failure rate), mainly for women and children;
- annual savings on fuelwood of 42,500 ton, on agricultural waste of 3,825 ton and on dung cakes of 2,550 ton;
- annual saving on kerosene of 830,000 litres;
- annual reduction in CO<sub>2</sub> emissions of 85,000 ton;
- significant annual savings on plant nutrients (NPK) and organic matter then available to improve soil fertility;
- significant improvement of health by the attachment and use of 8,750 toilets to biodigesters; by the reduction of indoor air pollution and smoke exposure benefiting especially women and children;
- generation of employment in the rural areas; at the end of the programme in total 2,700 manyears will be required to run the programme.

Although most of the early adopters of biodigester technology are expected to be the larger and medium farmers, smaller farmers are also expected to be attracted. The flat rate subsidy policy favours smaller digester sizes and therefore smaller farmers more than the larger ones. In addition an active involvement of (I)NGO's in the promotion an extension of biodigesters on the basis of self-help, has the effect of brining biodigesters within the reach of even smaller farmers with the minimum required livestock. However, biodigesters will never directly benefit those without livestock and these are generally among the very poorest strata of the society.

Some of the costs and many of the benefits of the programme are in the non-market sphere and this makes it difficult to determine financial and economical values. Furthermore, the programme has a number of social benefits which are difficult to quantify and/or value. Assuming average market prices for fuelwood only, the rate of return of the investment has hardly attractive to the potential user and subsidy is needed. This becomes less when savings in nutrients are perceived by the users. This emphasises the importance of extension of use of biodigester effluent.

The programme runs a number of risks, some of which have been incorporated in the design of the programme. Lack of firm data makes it difficult to arrive at reliable predictions on effective demand and a more detailed analysis, supplemented by data from a survey on willingness and ability to pay, will be needed to confirm provisional indications and conclusions.

There is little information available on the presence of companies and masons in the provinces that fulfilling the conditions to participate in biodigester construction trainings. The programme might have to actively recruit technicians from the artisan sector, such as water jar makers, to form trained mason team and build-up production capacity.

Financial institutions present in the programme area are willing to participate in the programme but it is uncertain whether farmers are willing and able to accept the high interest rates for biodigester loans.

The financial resources required for a successful implementation of the proposed programme amount to some €7,685,000 considering an average digester size of 6m<sup>3</sup>. Of this amount €3,640,000 has to be financed by the users by their own means and/or through bank loans. The participating financial institutions have indicated that they have enough reserves to finance all loan demands.

DGIS/DMW is requested to fund the required expenses for programme (€1,582,500) and subsidy (€1,531,250) cost under the Asia Biogas Programme. SNV is requested to provide technical assistance to a total cost of €850,000 while the MAFF will contribute non-quantified means such as programme office accommodation, water and electricity.

## List of acronyms and abbreviations

- ACLEDA : Association of Cambodian Local Economic Development
- BoQ : Bill of Quantities
- BPO : Biodigester Programme Office
- CFSP : Cambodia Fuelwood Saving Project
- CWPD : Cambodian Woman for Peace and Development
- DAHP : Department of Animal Health and Production
- DGIS : Directorate General International Cooperation (Dutch Ministry of Foreign Affairs)
- FAO : Food & Agricultural Organization of the United Nation
- FDI : Foreign Direct Investment
- FIRR : Financial Internal Rate of Return
- HRT : Hydraulic Retention Time
- LPG : Liquefied Petroleum Gas
- MAFF : Ministry of Agriculture, Forestry and Fisheries
- MFI : Micro Finance Institute
- MIME : Ministry of Industry, Mines and Energy
- MJ : Mega Joule
- MoU : Memorandum of Understanding
- NBC : National Bank of Cambodia
- NBP : National Biodigester Programme
- NBPO : National Biodigester Programme Office
- NBSC : National Biodigester Steering Committee
- PBPO : Provincial Biodigester Programme Office
- UNDP : United Nation Development Programme
- UNICEF : United Nation Children's Programme
- SNV : Netherlands Development Organization
- TPC : Thaneakea Phum Cambodia Ltd.
- VSF : Vétérinaires Sans Frontiers
- R&D : Research and Development
- TJ : Tera Joule

## **Programme arrangement**

### **Executive summary**

### **List of acronyms and abbreviations**

## **1. Programme rationale**

1.1.1 Country background .....	12
1.1.2 Sectorial background .....	15
1.2.1 Energy situation in Cambodia .....	15
1.2.2 Current status of the biodigester programme in Cambodia.....	16

## **2. Programme description**

2.1 Programme objectives .....	18
2.1.1 Overall objectives .....	18
2.1.2 Specific objectives .....	19
2.1.3 Relation to National Poverty Reduction Strategy.....	19
2.2 Pilot area and construction target .....	20
2.2.1 Selection of pilot provinces .....	20
2.2.2 Biodigester potential in the pilot provinces .....	22
2.3 Biodigester model .....	23
2.4 Programme activities .....	25
2.4.1 Promotion .....	25
2.4.2 Extension .....	26
2.4.3 Training .....	27
2.4.4 Quality control and enforcement .....	28
2.4.5 R&D and standardisation .....	30
2.4.6 monitoring and evaluation .....	30
2.4.7 Institutional support .....	31
2.4.8 Management and technical assistance .....	31

## **3. Programme structure** .....

3.1 Government structure .....	31
3.1.1 Ministry of Agriculture, Forestry and Fisheries .....	31
3.1.2 Provincial Department of Agriculture .....	31
3.1.3 Department of Animal Health and Production .....	32
3.2 Programme organisation .....	34
3.2.1 National Biodigester Programme Office .....	34
3.2.2 National Biodigester Steering Committee .....	35
3.2.3 Provincial Biodigester Programme Office .....	36
3.3 Implementation arrangements .....	37
3.3.1 Conditions for implementation .....	37
3.3.2 Reporting .....	37
3.3.3 Monitoring .....	37
3.3.4 Evaluation .....	38

<b>4. Programme benefits, assumptions and risks</b>	
4.1 Gender .....	38
4.2 Environmental aspects .....	39
4.3 Poverty, employment and health .....	40
4.4 Assumptions and risks .....	41
4.4.1 Assumptions .....	41
4.4.2 External risks .....	42
<b>5. Financial aspects</b>	
5.1 Financial analysis of an average biodigester .....	42
5.2 Subsidy .....	44
5.3 Programme cost and financing .....	44

List of tables:

Table 1	Overview of the most important socio-economic indicators	Page 14
Table 2	Energy balance	15
Table 3	Projected construction targets	19
Table 4	Provincial selection matrix	21
Table 5	Distribution of cattle in the pilot area	22
Table 6	Distribution of pigs in the pilot area	23
Table 7	Digester volumes, daily feeding rates, gas production and cost	24
Table 8	Indicators for a successful programme implementation	41
Table 9	Daily and annual fuelwood savings per digester volume	37
Table 10	Basic data for the financial analysis of a 6m <sup>3</sup> digester	42
Table 11	Financial requirement	45

List of Annexes:

- Annex I : BoQ's and biodigester drawings of 4, 6, 8 and 10 m<sup>3</sup> digesters
- Annex II : Quality standards
- Annex III : Provincial guidelines

# 1. Programme rationale

## 1.1 Country Background

Cambodia covers approximately 181.035 square kilometres in the south-western part of the Indochina peninsula. It lies completely within the tropics; its southernmost points are only slightly more than 10° above the equator. Roughly square in shape, the country is bounded on the north by Thailand and by Laos, on the east and southeast by Vietnam, and on the west by the Gulf of Thailand and by Thailand. Much of the country's area consists of rolling plains. Dominant features are the large, almost centrally located, Tonle Sap (Great Lake) and the Mekong River, which traverses the country from north to south. Two mountain ranges of note include the Dangret range on its northern border with Thailand, and the Cardamom range in the west.

The country's highest point is Phnum Aoral - 1,810 m located in the Cardamon mountains while the lowest point is the Gulf of Thailand - 0 m. The Cambodian coastline stretches for 443 km.

Cambodia's climate - like that of the rest of Southeast Asia - is dominated by the monsoons, which are known as tropical wet and dry because of the distinctly marked seasonal differences. In summer, moisture-laden air--the southwest monsoon--is drawn landward from the Indian Ocean. The flow is reversed during the winter, and the northeast monsoon sends back dry air. The southwest monsoon brings the rainy season from mid-May to mid-October or to early November, and the northeast monsoon flow of drier and cooler air lasts from early December to March. The southern third of the country has a two-month dry season; the northern two-thirds, a four-month one. Short transitional periods, which are marked by some difference in humidity but by little change in temperature, intervene between the alternating seasons. Temperatures are fairly uniform throughout the Tonle Sap Basin area, with only small variations from the average annual mean of around 25°C. The maximum mean is about 28°C; the minimum mean, about 22°C. Maximum temperatures of higher than 32°C, however, are common and, just before the start of the rainy season, they may rise to more than 38°C. Minimum temperatures rarely fall below 10°C. January is the coldest month, and April is the warmest.

The total annual rainfall average is between 100 and 150 centimetres, and the heaviest amounts fall in the southeast. Rainfall from April to September in the Tonle Sap Basin-Mekong Lowlands area averages 130 to 190 centimetres annually, but the amount varies considerably from year to year. Rainfall around the basin increases with elevation. It is heaviest in the mountains along the coast in the southwest, which receive from 250 to more than 500 centimetres of precipitation annually as the southwest monsoon reaches the coast. This area of greatest rainfall, however, drains mostly to the sea; only a small quantity goes into the rivers flowing into the basin. The relative humidity is high at night throughout the year; usually it exceeds 90 percent. During the daytime in the dry season, humidity averages about 50 percent or slightly lower, but it may remain about 60 percent in the rainy period.

Ninety percent of Cambodia's population is ethnically Cambodian or Khmer. Other ethnic groups include Chinese, Vietnamese, Chams, and Laotian. The estimated total population in

2005 is 13.6 million while the estimated population growth rate is 1.8%. 38% of the population is below 15 years of age, 59% is between 15 and 64 while only 3% is 65 or older. Theravada Buddhism is the religion of 95% of the population; Islam, animism, and Christianity also are practiced. Khmer is the official language and is spoken by more than 95% of the population. Some French is still spoken in urban areas, and English is increasingly popular as a second language.

In spite of recent progress, the Cambodian economy continues to suffer from the legacy of decades of war and internal strife. Per capita income and education levels are lower than in most neighbouring countries. Infrastructure remains inadequate. Most rural households depend on agriculture and its related subsectors, fully 75% of the population remains engaged in subsistence farming.

Manufacturing output is concentrated in the garment sector, which started to expand rapidly in the mid-1990s and now employs more than 250,000 workers, but faces an uncertain future following the end of textile quotas at the end of 2004. The other main foreign currency earner is tourism; Angkor Wat is one of the country's international tourist attractions. Tourist arrivals were topping the one million mark for the first time in 2004. The service sector is heavily concentrated in trading activities and catering-related services.

Cambodia's real GDP grew at 5.5% in 2002 and 5.2% in 2003, with almost all of the growth coming from the garment sector. Growth in 2004 was also strong at 5.5%, with the garment sector providing the biggest input into GDP growth. Inflation moderated from 3% in 2002 to an estimated average of 1.3% over 2003. Inflation remained under control in 2004. The national currency, the riel, was relatively stable over 2002 but depreciated slightly against the U.S. dollar in 2003. The National Bank of Cambodia made a series of limited yet effective interventions in 2004 to keep the riel to dollar rate at roughly 4,000 to one. The economy is heavily dollarised; the dollar and riel can be used interchangeably. Cambodia remains heavily reliant on foreign assistance--about half of the central government budget depends on donor assistance.

New FDI levels fell steadily from 1999-2001. According to the National Bank of Cambodia (NBC), which tracks actual monies spent as FDI rather than simply the value of approved FDI programmes, in 2001 there was \$150 million in FDI. In 2002, the NBC recorded \$54 million in FDI. In 2004, FDI was measured officially at \$131 million, with over half of that being invested in the garment sector. The economy has a poor track record in creating jobs in the formal sector and the challenge will only become more daunting in the future since 50% of the population is under 20 years of age and large numbers of job seekers will begin to enter the work force each year over the next 10 years.

Cambodia is a constitutional monarchy, and its constitution provides for a multiparty democracy. The Royal Government of Cambodia, formed on the basis of elections internationally recognized as free and fair, was established on September 24, 1993.



## 1.2 Sectorial background

### I.2.1 Energy situation in Cambodia

Cambodia has few exploitable energy sources available other than biomass. Wood accounts for more the 80% of the total national energy consumption. The natural forest, the main source of fuel wood, has been severely degraded due to widespread logging and forestland conversion. Fossil fuels, mainly diesel and heavy oil, are imported for electricity production and for transportation. There are a small number of micro hydro-electric plants in use while the construction of 2 medium sized plants is under study. A World Bank supported rural electrification programme has recently been announced. The exploitation of offshore natural gas fields will not commence within the next five years

According to a study by the NGO Cambodian Women for Peace and Development (CWPD-Rural Women Survey Cambodia, 2001), the utilization of biomass-based energy (wood, charcoal and agro-residue) is with over 90% of all energy use, highest in the province of Takeo, Siem Reap and Kampot. With 60% biomass based energy use, urban Phnom Penh has the lowest figure. The amounts used are marginal and vary from province to province depending on the availability of the energy sources and the financial means of the population

The energy balance of Cambodia (1995) is dominated by high level of wood energy consumption as shown on the table below:

**Table 2:** Energy balance

	Type of fuel	TeraJoule	percent
1	Fuelwood	77,721	82.16%
2	Agricultural residues	1,624	1.72%
3	Dung	18	0.02%
4	Charcoal	1,097	1.16%
5	Electricity	827	0.87%
6	LPG	170	0.18%
7	Gasoline	6,089	6.44%
8	Jet Fuel	468	0.49%
9	Kerosene	1,112	1.18%
10	Diesel fuel	5,401	5.71%
11	Fuel oil	65	0.07%
	TOTAL	94,592	

Consumption of wood (based) energy and other biomass is high at 85.06% of national energy consumption. The distribution of wood based energy consumption is mainly in the household sector that consumes about 79,906 TJ and it is representing 84.47% of national energy consumption. Household energy consumption is divided into rural households that consumes 74,449 TJ and urban household consuming 5,457 TJ.

Altogether, fuelwood and charcoal are representing about 96.3% of all cooking fuel consumed in this country.

One of the reasons why many families prefer to burn fuelwood and charcoal is economic value. The price of fuelwood and charcoal in Cambodia is low compared to other energy carriers. The price of charcoal is depending on the location, 600 - 800 riels per kg or around US\$ 0.15 to US\$ 0.20, while the price of kerosene is 1,800 riels per liter or around US\$ 0.45 (exchange rate US\$1 = 4,000). Though the efficiency of devices to burn fuelwood and charcoal is quite low, the cooking energy cost for each useful energy (MJ/kg) is still lower than the same cost of kerosene or LPG burned in a high efficient stove.

A CFSP inquiry found an average rural household consumption of 1.2 *steres*<sup>1</sup> of wood/month or 14.4 *steres*/year (Social Energetic Study, 1998). This is equivalent to 14.4 kg of wood/household/day, or 2.57 kg/capita/day (average family size is 5.6 people).

Former surveys in Cambodia (MIME, 1996), carried out in other provinces, give 9.56 kg/household/day or 1.7 kg/capita/day for rural domestic wood consumption.

A FAO survey carried out in Siem Reap province, near Tonle Sap big lake (FAO, 1998) finds an average firewood consumption of 14 *steres*/household/year, which is a data very close to CFSP estimate. CFSP current estimates come from user interview; CFSP is planning to start soon with field measurements for confirmation.

According to a survey of the FAO (November 2000), the quantity of wood required to satisfy people's basic energy needs for one year in rural Cambodia amounts to: 0.46 tonnes of wood and 0.12 tonnes of charcoal per person per year. Given that 1 kg of charcoal is equivalent to 3.7 kg of wood, the wood consumption is 2.5 kg/day. This figure is very near to the CFSP figure.

For rural domestic sectors, household consumption and domestic palm sugar production, fuel wood is collected directly by users in their surrounding environment which may consist of nearby forests, woodlands or shrub lands depending on settlement location. In the southern provinces where fuel wood resources become increasingly scarce, fuel wood is also bought from commercial rubber palm plantations.

Commercial fuel wood that flows along trading channels mainly comes from more dense ecosystems that are evergreen upland forest, deciduous, mixed, and flooded forests. Some woodcutters in those forests are farmers who sell fuel wood as an additional income generating activity only during the dry season (November – June). For other cutters, fuel wood trading seems to be their main income generating activity made during the whole year.

### 1.2.2 Current status of the biodigester programme in Cambodia

The first contacts with Cambodian authorities were established in June 2004 during the Conference for Renewable Energy in Bonn, Germany. This visit was followed up by a first identification mission in July and a feasibility study in November 2004.

The feasibility study came to the following main findings and recommendations.  
Findings:

---

<sup>1</sup> **Stere** = 1 cubic metre of stacked wood. 1 stere equals 360 kg of air dried wood when firewood, 1 stere = 450 kg of wood when processed into charcoal.

- The domestic consumption of fuelwood is not balanced by a sustainable production;
- The majority of the households own two or more cattle used for draft power and for financial security. The average farmer will also own some pigs for income generation.
- Most farmers till small plots of land to satisfy the families need for rice and vegetables. The quality of the arable land is mostly poor; the average rice yield per hectare is 1.3 tonnes compared to 3 tonnes in the neighbouring countries.
- Biodigester technology can play an important role to improve the quality of life for the rural households, especially for women, by reducing indoor air pollution and reducing the daily workload, and as a tool in an integrated farming system by using the full potential of digester effluents;
- A conservative estimate of the technical potential for domestic biodigesters in the 6 selected provinces amounts to 224,000 units.

#### Recommendations:

- A National Biodigester Programme needs to be established to come to the commercial and structural deployment of biodigester technology. The most appropriate ministry should host such a programme with direct linkage to the target population and with the most extensive infrastructure, i.e. the Ministry of Agriculture, Forestry and Fisheries (MAFF).
- To gain the confidence of the market in the technology, there must be a strong focus on quality. This includes quality of information, construction and after-sales service. Brick dome digesters appear to be the most suitable design when it comes to reliability and possible use of CDM revenues. The availability of material allows for the introduction of such digesters. Applied research is necessary to come to an enforceable national standard for biodigesters.
- A mechanism needs to be established to make reasonable finance available for domestic biodigesters. Preferably, this finance has to be channelled through existing and regulated banking institutes, i.e. Association of Cambodian Local Economic Development (ACLEDA) and the Micro Finance Institution AMRET. Provision of subsidy will be an important marketing tool and must be linked to pre-defined quality standards.
- For the actual construction and for the after-sales service of biodigesters, the establishment of local biodigester enterprises must be encouraged. This includes training of technicians and management support.
- Research on the use of the full potential of digester effluent and dissemination of the research results must be an important and integrated part of the programme.
- SNV, with its experience with this type programme development should ensure the provision of technical assistance to the programme and to the various institutes, aiming at capacity building of the respective organizations.

Based on the above findings and recommendations of the feasibility study, Cambodia was included in the Asia Biogas Programme proposal. This proposal, aiming to provide access to biogas for 1.3 million people in Asia over the period 2005 up to 2011, was submitted by SNV to DGIS/DMW in November 2004. The Dutch Minister for Development Cooperation signed a Memorandum of Understanding on the co-financing of the proposal with SNV on 14 December 2004.

A MoU on the technical assistance for a National Biodigester Programme was signed between SNV and MAFF on May 25, 2005 and since July a SNV biogas advisor is stationed in Phnom Penh. In this period a National Biodigester Programme Office has been established within the premises of the Department of Animal Health and Production, a unit of MAFF. As part of the preparation for the implementation of a national programme the following activities have been undertaken:

- A biodigester fixed dome model suitable for mass dissemination in Cambodia has been selected and further adapted to the local conditions.
- Biodigester appliances such as stoves and taps have been adapted to locally available materials and workshop facilities and are now in production.
- A biodigester technical training centre has been established within the premises of a polytechnic institute. In this centre biodigester masons and supervisors will be trained. As part of training for trainers programme and for demonstration purposes, nine biodigesters of various sizes have been built.
- Consultations rounds have been held with representatives from MAFF and the different provinces on the implementation of the programme.

## **2. Programme description**

### **2.1 Programme objectives**

#### **2.1.1 Overall objectives**

The overall objective of the first phase of the National Biodigester Programme is the dissemination of domestic biodigesters as an indigenous, sustainable energy source through the development of a commercial, market oriented, biodigester sector in selected provinces of Cambodia.

The main benefits are as follows:

- reduction in the rate of deforestation and environmental deterioration by substituting fuelwood, agricultural waste and in some cases dung cake to meet the energy demand of the rural population;
- improvement of hygiene and health of the rural population, especially of women and children, by elimination of smoke produced during cooking on fuelwood and by stimulation better management of dung and night soil by attachment of latrines;
- improvement in the long run of the financial situation of households by eliminating the need to buy expensive fuelwood;
- increase of agricultural production by promoting optimum utilisation of digester effluent as organic fertiliser.

### 2.1.2 Specific objectives

The specific objectives of the first phase of the National Biodigester Programme contributing to its overall objective are:

- To increase the number of family sized, quality biodigesters with 17,500 in selected provinces;
- To ensure the continued operation of all biodigesters installed under the biodigester programme;
- To maximise the benefits of the operated biodigesters, in particular the optimum use of digester effluent;
- Technical and promotional capacity development for further wide scale deployment of biodigester technology in Cambodia;
- To strengthen and facilitate establishment of institutions for the continued and sustained development of the biodigester sector.

Indicators for the successful achievement of the objectives are given in chapter III.3.3

The target group (market) for the programme are farmers who have on a daily basis a minimum of 15 kg of animal waste at their disposal. This amounts to the daily dung production of 2 average head of cattle or 4 adult pigs.

The construction targets and programme period are as follows:

**Table 3:** Projected construction targets

2005	2006	2007	2008	2009	
Preparation	Implementation				
0	I	II	III	IV	Total
Province I	400	800	1500	2000	4700
Province II	300	650	1500	2000	4450
Province III	300	650	1000	1500	3450
Province IV		300	500	500	1300
Province V		300	500	1000	1800
Province VI		300	500	1000	1800
<b>Total</b>	<b>1000</b>	<b>3000</b>	<b>5500</b>	<b>8000</b>	<b>17500</b>

### 2.1.3 Relation to National Poverty Reduction Strategy

According to Cambodia's Poverty Reduction Strategy paper, the following topics mentioned are directly or indirectly positively affected by the programme:

#### 1. Promoting Agricultural Development:

- strengthen capacity and improve knowledge system within the Government, stakeholders, and especially within small-scale farmers;
- promote intensification, diversification and security of agricultural production;

- fertiliser application in order to maximize agricultural production that would ensure achievement of food security and income generation for the farmers;
- reduce rate of animal disease and mortality;
- establish National Livestock Research Centre and regional/provincial farmers' livestock learning farms, which allow for the development of appropriate technology for animal raising and feeding.

2. Expanding Job Opportunities:

- Promotion of Private Sector Development, especially of small and medium enterprises who are seen as 'engines of growth'.

3. Improving Rural Livelihoods:

- Improvement of the health situation by reducing the levels of indoor air pollution and the provision of improved toilet facilities (according the 1998 census, only 8.6% of the rural population has access to improved toilet facilities)

4. Gender Disparities:

- Reducing the workload for women.

5. Natural Resource Management:

- Sustainable use of forest products.

## **2.2 Pilot area and construction target**

### 2.2.1 Selection of pilot provinces

A new national biodigester programme will start with a pilot to gain experience and to fine-tune the programme set-up. Such a pilot has the highest chance of success in provinces most suitable for biodigester dissemination. These provinces have been selected by means of a matrix where the most important factors, livestock numbers, availability of fuel wood, economic standards, number of house holds and livelihood are compared. The outcome of this exercise is given in the table below.

**Table 4: Provincial selection matrix**

Province	Demo-graphics	Dung Availability	Fuel Availability	Spending Ability	Access to Water	Flooding	Total	Overall Rank
	No Rural House holds	Number of Livestock	Forest Cover	Motorbike Ownership	Access <150m	Flood Rating		
	<b>Rating of Individual Characteristic</b>							
Kampong Cham	1	1	6	7	3	11	29	1
Svay Rieng	10	5	4	3	1	9	32	2
Prey Veng	2	2	2	10	2	15	33	3
Kampong Speu	7	4	8	5	8	3	35	4
Takeo	4	3	3	5	10	13	38	5
Kandal	3	8	5	2	13	7	38	6
Phnom Penh	15	14	1	1	12	2	45	7
Kampong Chhnang	11	9	7	12	6	4	49	8
Siem Reap	6	6	12	16	5	8	53	9
Kampot	9	7	11	12	15	5	59	10
Kratea	13	13	14	6	9	6	61	11
Kampong Thom	8	10	10	15	7	12	62	12
Sihanouk Ville	14	15	15	14	4	1	63	13
Battambang	5	11	9	8	16	14	63	14
Pursat	12	12	13	13	11	10	71	15
Kep	16	16	16	9	14	-	71	16

Based on a rating per province where 1 represents the province with the most favourable conditions for biogas dissemination. There are 20 provinces and 4 municipalities in Cambodia. Provinces more than 6 hours by road from Phnom Penh were screened out due to poor access. Six provinces in the vicinity of Phnom Penh have been selected for the biogas programme implementation, i.e. Kampong Cham, Svay Rieng, Prey Veng, Kampong-Speu, Takeo and Kandal.

Out of these 6 provinces 3 have been selected for the first year of implementation: Kampong Cham, Svay Rieng and Kandal.



### 2.2.2 Biodigester potential in the selected provinces

Vétérinaires Sans Frontiers (VSF) has conducted an extensive study on livestock rearing practices in 3 of the 6 selected provinces. In the provinces Svay Rieng, Prey Veng and Takeo over 1000 rural households were interviewed on the number of pigs and cattle they own. Extrapolating the outcome over the 6 provinces gives the following results:

**Table 5:** Distribution of cattle in the pilot area

Estimated distribution of buffalo and cows over rural households				
# animals per hh	%	# cattle in pilot area	# cattle national	# families in pilot
0	29.8			339,100
1	20.7	235,900	464,800	235,900
2	27.0	614,100	1,210,000	307,000
3	12.2	417,200	822,100	139,100
4	6.9	312,200	615,200	78,100
5	2.0	112,000	220,600	22,400
6	0.9	61,600	121,300	10,300
7	0.3	24,300	47,800	3,500
8	0.1	11,200	22,100	1,400
9	0.1	6,000	11,800	700
10	0.0	4,800	9,400	500
	100	1,799,300	3,545,100	1,138,000
Estimated number of families with sufficient dung for biodigester				563,000

The six selected provinces have 51% of Cambodia's cows, buffalos and pigs. Cattle are kept for beef, for draft power and as safekeeping of financial resources. There are practically no dairy cattle. There is a great variety in the size, condition and breed of the cattle population. It is common practice during the paddy-growing season to keep the cattle at the farmyard; this lasts for about 6 months. During the rest of the year the cattle are roaming free during the day and kept at the farmyard during the night. The dung produced at the farmyard is collected to be used as fertilizer. Depending on the season, type of animal and the housing of the animals, 5 to 15 kg of dung can be collected per animal per day.

Pigs are kept in confined places that vary widely in quality, ranging from the animals being tied with a rope to a tree or pole to covered pigsties with a hard floor. Pig dung is considered a waste product as it is usually disposed of in surface water. Pigs are sold for slaughter when they are about 100 kgs. The average weight of the pig population can be estimated at 60 kgs i.e. the average pig will produce about 4 -6 kgs of dung per day, depending on feeding practices.

Based on the same source as for the cattle distribution, the table below gives the distribution of pigs over the rural households in the pilot area.

**Table 6:** Distribution of pigs in the pilot area

Estimated distribution of pigs over rural households				
# animals per hh	%	# animals in pilot area	# animals national	# families in pilot
0	22.6			186,300
1	50.8	419,000	818,300	419,035
2	16.4	270,300	527,800	135,100
3	5.2	129,000	251,600	43,000
4	2.0	67,000	130,800	16,800
5	1.0	41,500	81,000	8,300
6	0.5	25,100	49,000	4,200
7	0.4	22,800	44,500	3,300
8	0.2	16,100	31,400	2,000
9	0.2	15,300	29,900	1,700
10	0.2	12,700	24,800	1,300
11	0.2	14,500	28,400	1,300
12	0.1	9,200	17,900	800
13	0.1	11,800	23,000	900
14	0.0	5,500	10,800	400
	100	1,059,800	2,069,200	824,435
Estimated number of families with sufficient dung for biodigester				41,000

Practically all farmers who own cattle will also have pigs and it can be safely concluded that at least 25% of rural families have enough raw material available to feed a biodigester. The average size will be small, between 4 to 8m<sup>3</sup>; also because of the favourable temperatures the year round which allows for a relatively short hydraulic retention time (HRT) of 30 days. Based on the VSF survey this amounts to 224,000 families.

### 2.3 Biodigester model

There are no biodigester models that have been successfully introduced and disseminated with reasonable numbers in Cambodia. Over the past 10 years a number of organisations, both Governmental and NGO's, have tried to introduce plastic bag biodigesters mainly because they are cheap. However, these attempts have failed due to the vulnerability of the plants and the constant need for repair. A few fixed dome digesters have also been built, notably the Chinese model through a cooperation agreement with the Chinese Government, but little has been done in the training of local technicians.

This means that the National Biodigester Programme has to start from scratch in the training of technicians and supervisors as well as with promotional activities. Also a model fit for mass dissemination had to be identified.

SNV-Cambodia requested the services of an independent engineering consultant to evaluate 5 different fixed dome models, used in the Asia region, on their appropriateness for mass dissemination in Cambodia. The evaluation criteria were: availability of materials, degree of building complexity, durability and maintenance demand, ease of use, appropriateness for construction in areas with a high water table, and cost.

The recommended model is the Deenbandhu plant originating from India. This model has meanwhile been modified to suit the Cambodian conditions, the gas storage capacity has been increased to 50% of the nominal daily gas production and the outlet has been modified. This adapted model has been baptised the ‘Farmers Friend Biodigester’ or in Khmer ‘Lor Chiveak Ouksmann Met Kaksekor’. At the time of writing of this document, 10 plants varying in sizes between 4 and 10 m<sup>3</sup> are under construction for research and training purposes.



A 6 m<sup>3</sup> Farmers Fried biodigester under construction at the Royal University of Agriculture in Phnom Penh

Table 7, here below, gives the different volumes, daily feeding rates, gas production as well as the cost.

**Table 7:** Digester volumes, daily feeding rates

Plant volume [m <sup>3</sup> ]	4	6	8	10
Daily feeding* [kg dung]	20-40	40-60	60-80	80 +
Daily gas production [m <sup>3</sup> ]	0.8-1.6	1.6-2.4	2.4-3.2	3.2 +
Cost [US\$]**	292	337	385	438
Fuelwood replacement value [kg/day]	4- 8	8-12	12-16	16 +

\*) Based on a hydraulic retention time (HRT) of 40 days

\*\*\*) Including 15% overhead and guarantee

The bill of quantities for the different sizes as well as the basic construction drawings are given in annex 2

## **2.4 Programme activities**

### **2.4.1 Promotion**

An essential part of any marketing strategy for biodigesters is and will remain the quality of the product and the services. As the investment for a biodigester is high, low quality plants with a short lifespan cannot be accepted. Furthermore a well functioning plant is the best possible promotion and the satisfied user the best possible promoter for biodigester technology. Therefore, control of quality regarding plant sizing, construction, user training on operation and maintenance and after-sales services will be of utmost importance, especially during the pilot phase of the programme.

At the moment biodigester technology is hardly known in the rural communities and the promotional activities are in first instance aimed at introducing the technology at a broad public.

The working model followed for biodigester promotion and marketing consist of 6 phase, briefly described here below.

#### *Phase 1: Promotion*

Target group: all potential users

Aim: to create awareness on the advantages of biodigester technology and to raise interest in biodigester technology

Means: mass communication, after-sales service, and subsidy

#### *Phase 2: Information/education*

Target group: potential users with differentiation in economical class and sex

Aim: to raise active interest of potential users in a way that they can evaluate the advantages and disadvantages for the possible adoption of biodigesters for their particular situation

Means: group approach communication with use of extension workers, company-to-farmer communication

#### *Phase 3: Personal persuasion*

Target group: potential users who have shown active interest in biodigesters

Aim: to give the final 'push' for adoption

Means: personal communication from extension worker to potential user and farmer-to-farmer, company-to-farmer communication

#### *Phase 4: Decision/adoption*

The period between awareness and adoption is influenced by economical and social/cultural factors and by the individual characteristics of the adopter.

#### *Phase 5: Training*

Target group: users (men and women)

Aim: to provide the necessary knowledge and skills for the proper O&M to use the plant efficiently and effectively

Means: training on the spot or elsewhere

### Phase 6: After-sales service

Target group: users (men and women)

Aim: to have good functioning plants in operation with satisfied and positive users, leading to farmer-to-farmer motivation

Means: fast and reliable service after user complaint and regular (at least yearly) visits with emphasis on O&M

In the above model promotion (Phase 1) raises general awareness; information and education (Phase 2) to evaluation; personal persuasion (Phase 3) to decision; adoption (Phase 4) to use; training (Phase 5) to effective use; and after-sales service (Phase 6) will keep the plants in good function which is a precondition for the promotion of biodigesters (Phase 1).

The following activities are foreseen:

- Biodigester programmes will be made for broadcasting on local radio (phase 1);
- Village information workshops will be conducted in villages with a high biodigester potential (phase 2);
- Pre-construction trainings and involvement of NGO's to introduce biodigester technology in their programmes/programmes (phase 2 & 3);
- Develop and placard promotional posters and distribution of leaflets (phase 1, 2 and 3);
- Provision of subsidy (phase 3).

The lead organisation for the promotional activities are the PBPOs, however, promotion activities can also be undertaken by other organisations such as (I)NGOs, line agencies and MFIs. Biodigester promotion on a national level will be a task for the NBPO.

### 2.4.2 Extension

Where promotion relates to activities to be undertaken before the construction of a biodigester, extension is focussed on activities - apart from after sales - needed after installation. Proper training of especially female users on operation and maintenance does not only benefit the users but also the biodigester masons in reducing their workload in after sales. The programme will provide modest financial support for development of extension materials and users group trainings.

Use of biodigester effluent has to be an integral part of the plant's overall use. The programme will conduct research on how the effluent use can optimise the benefits of the digester. Extension materials have to be developed and distributed while agricultural extension staff needs to be trained on the most beneficial effluent use.

Connection of a toilet to the biodigester is most advisable to improve the hygienic conditions of the households. In case the farmer would reject the connection of a toilet presently for cultural reasons, the possibility for connection shall remain open by providing a second inlet pipe during the construction. Cooperation will be sought with existing sanitation programmes, i.e. the UNICEF Water, Environment and Sanitation Programme, in popularising the use of biodigesters for human waste treatment.

### 2.4.3 Training

Being a new programme, introducing a new technology, training is a vital component for the smooth implementation. During the preparation of the programme much attention has already been given to the development of training curricula and material as well as to the training of trainers.

The following training courses and targets are scheduled:

#### Masons (50 days):

Training of masons will have a high priority because the masons will be the back-bone of the programme. Besides the technical part of the training (construction, maintenance and repair) the masons will also be trained on promotion (how to attract new clients), plant sizing, user extension (how to explain to the user operation and maintenance tasks, including trouble shooting and small repairs) and feed-back from users. The training is divided in 2 parts, a 10 day training at a centrally located Biodigester Technical Training Centre and 40 days (the time required to complete 2 plants) at field level.

#### Mason refresher training (4 days):

Trained masons who are active in the biodigester construction will receive refresher training. Preferably every mason should get such training after one year of the completion of his mason training. If the quality of a mason's work is not good enough, additional training can be made compulsory.

#### Supervisors training (8 days):

The biodigester companies have the final responsibility of the construction of the biodigester plants while PBPO staff will perform quality control work on sample basis on behalf of the programme. There fore both organisations will have supervisors who can inspect the plants on quality and, if necessary, instruct the masons on improvements to be made. The supervisors will be trained at the Biodigester Technical Training Centre on inspection and quality control.

#### Supervisor refresher training (4 days):

Like with the mason refresher training also here active supervisors will be invited to attend a refresher course 1 year after completion of their supervisor training. During this training the participants will acquire a more in-depth understanding of biodigester technology while also attention will be focussed on the programmatic aspects.

#### Staff of PBP offices (4 days):

The PBPOs will be responsible for the planning, implementation and reporting of the programme on provincial level. For the staff of the offices, appointed by the Department of Agriculture, workshop/training will be organised to introduce them to the programme and to train them in the proceedings and regulations.

#### Managers training (4 days):

PBPO and company managers will be trained in marketing, promotion and quality management.

Study tours:

Study tours in the region (especially Vietnam) will be organised to for people working in the sector to learn from experiences elsewhere.

MFI, Bank, (INGOs and Line agencies extension and promotion training (2 days):

Extension staff of financial institutions (INGOs as well as extension staff of line agencies (agriculture, forestry, health, women affairs) are expected to play a very important role in the promotion and use of biodigesters. Staff of these organisations will be trained on the basics of biodigesters, the roles of the different actors, quality standards and how to promote and extend biodigesters to potential users.

Pre-construction user training (1 day):

During this training potential users will be explained what the advantages and disadvantages of biodigesters are. A strong focus will be on the input requirement for feeding and the financial consequences. Also it will be explained what the procedures are if people want to acquire a plant under the programme.

Post-construction user training (1 day):

The functioning of a biodigester and its overall efficiency is for a large part determined by the user's operation and maintenance of the plant. Apart from the instructions from masons and supervisors, groups of (mainly) female users will be trained on how the plant works, what output can be expected, how to use the effluent and what maintenance activities are required.

Training of trainers (4 days):

The trainers of the user trainings will be trained on how to extend the users on the operation and maintenance of the plants and on cooking practices and conditions for maximum effectiveness.

Training activities will be, when ever opportune, contracted to appropriate institutes like polytechnics, NGOs and consulting firms.

#### 2.4.4 Quality control and enforcement

Companies and mason teams who wish to cooperate with the PBPO and benefit from the subsidy scheme, will be required to seek recognition from the PBPO office. Such recognition is subject to a series of strict conditions such as:

- approval of standard design and sizes of biodigesters;
- trained, certified and registered masons for the construction of biodigesters;
- construction of biodigesters on the basis of detailed quality standards;
- provision of NBPO approved quality biodigester appliances (pipes, valve, stove, water trap, lamp);
- provision of proper user training and provision of a user instruction manual;
- provision of one year guarantee on appliances and two years guarantee on the civil structure of the biodigester, including an annual maintenance visit during the guarantee period;
- timely visit of a technician to the biodigester in case of a complaint from the user;
- proper administration.

These conditions will be put down in an agreement between the PBPOs and the biodigester companies and mason teams.

Quality control on plants in operation and under construction is a key aspect of quality enforcement and the long-term success of the programme. The controls will be conducted by supervisors of the Provincial Biodigester Programme Offices (PBPOs) with regular assistance from the National Programme Office Engineers.

Because all masons are new in the art of digester construction, 50% of all registered plants will be inspected in the first year of activities in a province. This ratio will gradually decline as more experience is gained in the provinces and when the overall quality level is considered to be satisfactory. The PBPOs will receive a remuneration of 15 US\$ per inspected plant. Of the inspected plants an inspection form will be filled out and the resulted date will be entered in a data base to monitor the results over time. Masons and/or companies with less than satisfactory performance will be facilitated in upgrading their skills. If the poor performance is persisting they will be eliminated from the programme.

After sales service is an integral part of the product delivered by the mason teams and biodigester companies. The after sales service include proper instruction of the user on the operation of the plant and maintenance as well as a 1 year guarantee on appliances and 2 years on the civil structure of the plant. The guarantee provision includes at least 2 visits with a 1 year interval, starting 6 months after the completion of the plant. The instruction of the user will include the following aspects of plant operation and maintenance:

- proper feeding of the plant;
- proper use of biodigester;
- regular simple maintenance like cleaning of the burner, changing the mantle of the lamp and the use of the water trap;
- proper use of the plant effluent;
- cooking habits and cooking environment.

The above mentioned topics are all equally important for an effective use of the plant and its outputs and for the overall impact of the biodigester programme. The training of users, including some simple trouble shooting, will therefore get due attention. This will be a task for biodigester masons and supervisors who are most in contact with the users but also for the extension workers from (I)NGOs, financial institutions and line agencies.

Besides training of users during the construction work, commissioning of the plant and maintenance visits, new plant owners will also be invited to participate in a 1 day post construction user training organised by the PBPO. During this training the emphasis will not only be on operation and maintenance but also on financial aspects and owners rights.

User instruction manuals will be developed and distributed by the mason groups and companies to the users.

#### 2.4.5 R&D and Standardisation

Applied technical research into areas as product innovation, standardisation, testing of new design and developments, monitoring and measuring plant performance determinants of demand for biodigesters, etc. will be necessary for the programme to improve, update and adapt to changing circumstances. More specific applied research activities to be carried out include the following:

- Effluent R&D will consist of exchange with and study visits to other biodigester programmes in Asia as well as applied research within Cambodia on the optimal use of effluent as fertiliser. This will be in a wet form integrated into irrigation systems for paddy farming and in semi dry, composted form, for vegetable farming. Also research will be done on the best possible way to conduct effluent extension work and on the development of extension material;
- development and testing of alterations on the biodigester plant design, including the gaspipe, in order to make them more efficient, better adapted to the Cambodian farmer and/or lower in cost;
- development and testing of appliances that can be manufactured locally, this includes gas tap, stove, lamp and water trap;
- solving technical problems related to the construction, operation, maintenance of biodigester plants and appliances;
- standardisation of biodigester plant and appliances designs as well as construction and manufacturing methods;
- studies to assess the impact of biodigester use on households; determining savings on traditional fuels like wood and kerosene, on chemical fertiliser and the impact on crop production.

In principle research and development activities will be contracted to research institutes and consulting firms on the basis on ToRs elaborated by the NBP office and programme proposals by the above mentioned parties.

#### 2.4.6 Monitoring and evaluation

In addition to more technical R&D, monitoring of the programme activities and evaluation will be conducted. Some of the activities are:

- CDM baseline study to determine the effect of the programme on CO<sub>2</sub> equivalent emissions by improved manure management and replacement of fuelwood;
- user surveys to study field experiences especially in relation to the impact on women;
- surveys on the experiences with effluent use;
- surveys to analyse the willingness and ability to pay to determine the effective demand;
- surveys why farmers do not install a biodigester;
- evaluation of the performance of financial institutes in the credit provision for biodigesters;
- evaluation of the quality of the after sales service;
- evaluation of trainings like user's pre and post-construction training and extension activities.

Monitoring and evaluation activities will be contracted to research institutes and consulting firms on basis of ToRs elaborated by the NBP office.

#### 2.4.7 Institutional Support

The programme will seek the involvement of existing Government offices, (INGO's, financial institutions and private enterprises. If there will be a structural and long-term involvement of these parties support, both financial support as well as advice can be provided by the programme to enhance the capacity of the involved parties. This support will be based on proposals with clear objectives submitted by the concerned party.

#### 2.4.8 Management and technical assistance

On a national level the management, coordination, reporting and financial administration is the task of the National Biodigester Programme Office. This office will have an estimated staff number of ten and will be supervised by the National Steering Committee, chaired by an appointee of MAFF.

SNV-Cambodia provides technical assistance to the programme in the form of a permanent Sr. Biodigester Advisor. Other advisors will be deployed on a temporary basis if the need arises.

### **3. Programme structure**

#### **3.1 Government structure**

##### 3.1.1 Ministry of Agriculture, Forestry and Fisheries (MAFF)

The Ministry of Agriculture, Forestry and Fisheries of Cambodia has as mandate to direct and establish the agriculture sector development plans as well as coordination, monitoring and evaluation of the implementation of policies and activities for development of agriculture. The Ministry coordinates and cooperates with national and international governmental organisations. In May 2005, the Ministry has signed a MoU with SNV on the development of a national biodigester sector, based on the feasibility study report of January 2005 and the Asia Biogas Programme proposal of November 2004.

##### 3.1.2 Provincial Department of Agriculture (PDoA)

On provincial level the Ministry is represented by the Department of Agriculture (DoA). The DoA plans and promotes the implementation of all agricultural activities within the province following MAFF policies. The department is headed by a director who has the overall management and who is responsible in front of the Minister of MAFF and the Provincial Governor.

### 3.1.3 Department of Animal Health and Production (DAHP)

The Department of Animal Health and Production is one of 14 departments within the Ministry. DAHP has been mandated by MAFF to formulate and prepare the policies and planning of programmes and programmes related to the development of the animal health and production sub-sector. This includes the management of animal waste and therefore DAHP has become the host of the National Biodigester Programme. The Department has allocated office accommodation to the programme at its national premises.

#### Organisation chart of MAFF

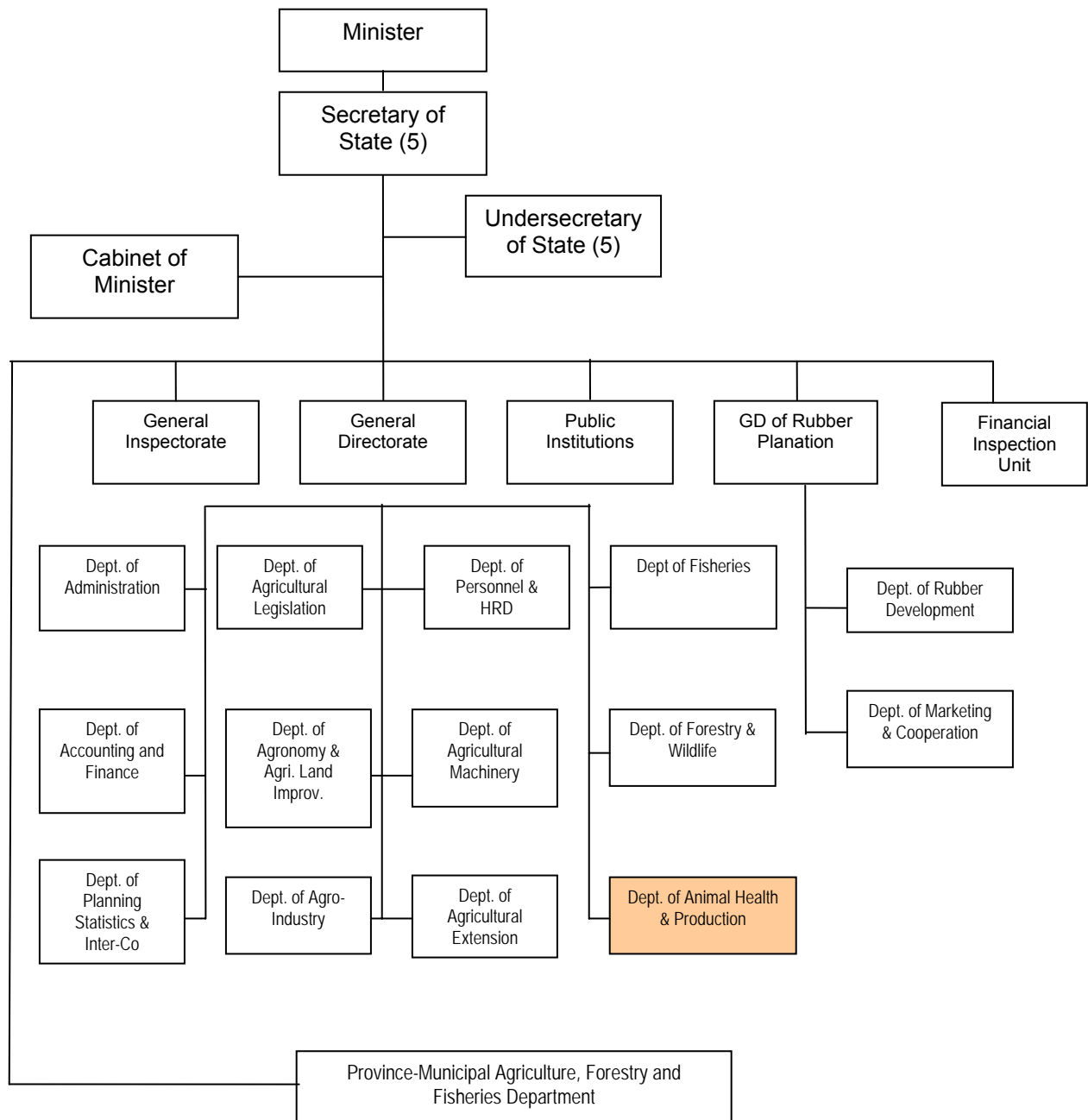

## Organisational chart of the PDoA

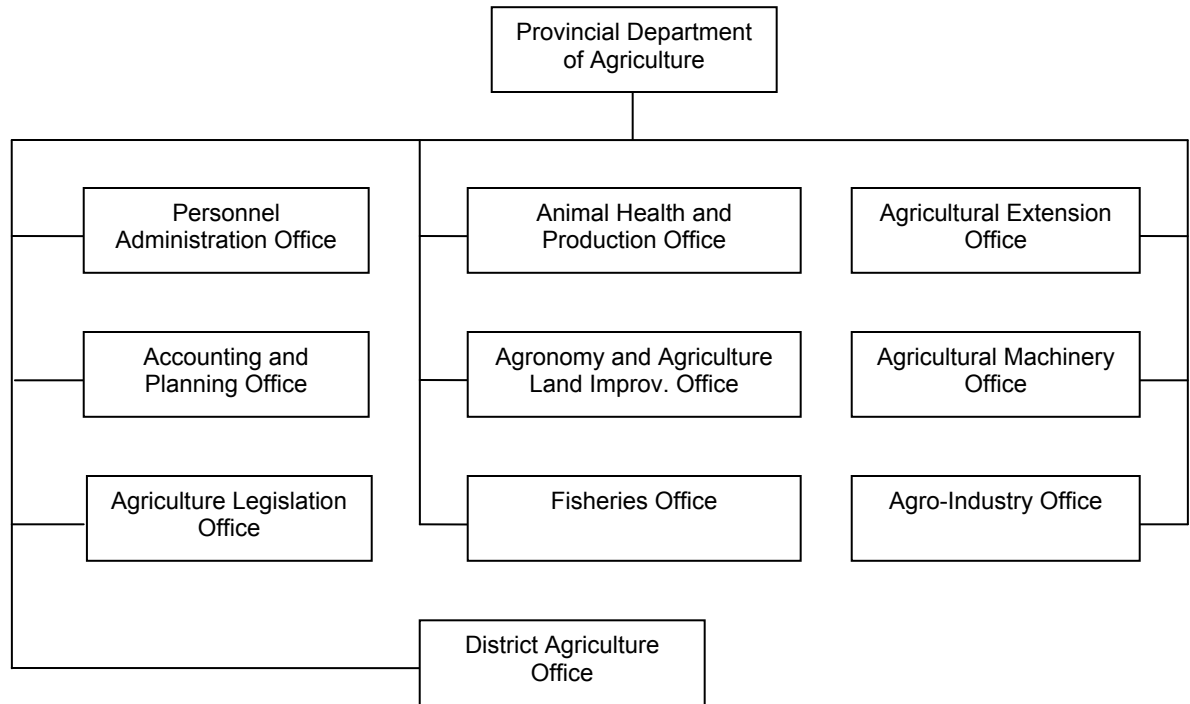

### 3.2 Programme organisation

#### 3.2.1 National Biodigester Programme Office

The National Biodigester Programme Office (NBPO) leads the whole programme and responsibility for development and direction of the National Biodigester Programme Cambodia. Main activities include promotion, coordination of trainings, subsidy channelling and administration, applied research and development, quality management and effluent use development and extension. The NBPO monitors and supports the activities of the Provincial Biodigester Programme Offices (PBPO's).

**Organisational chart of the National Biodigester Programme Office**

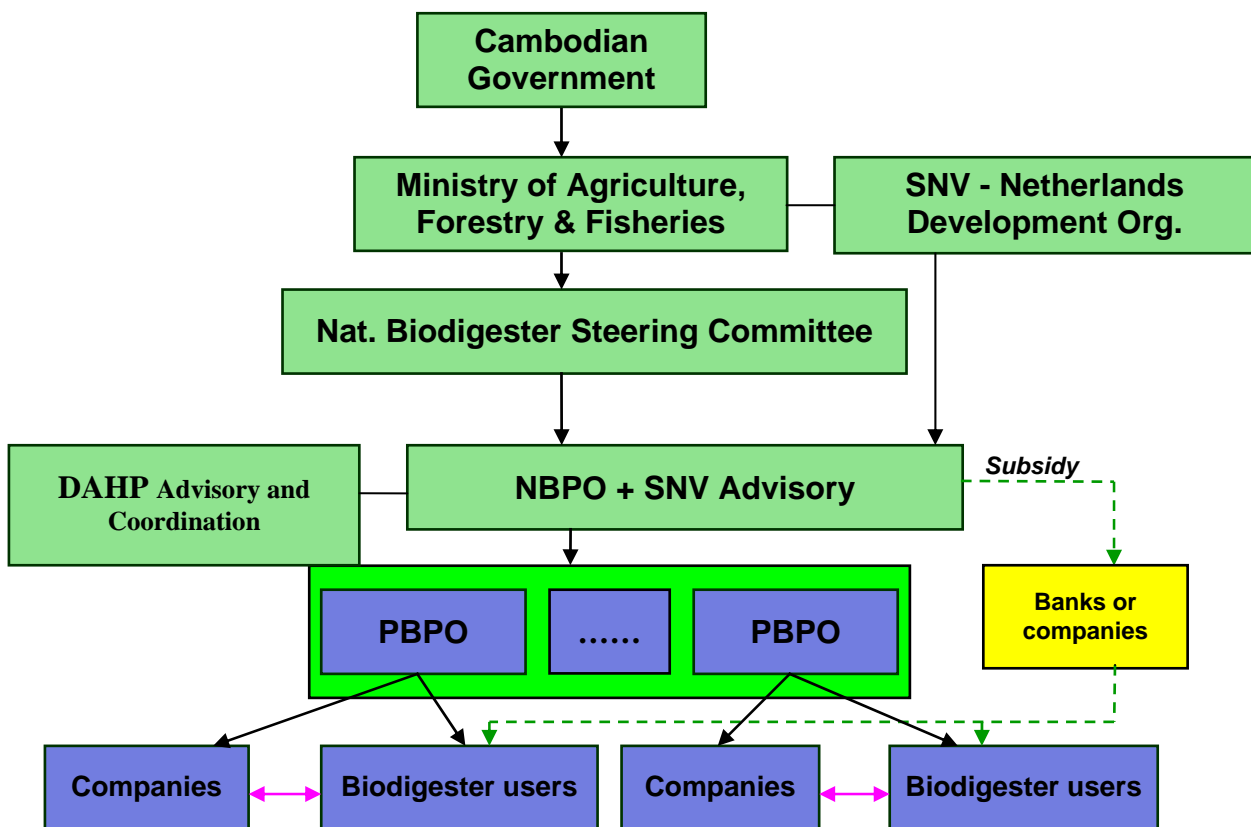

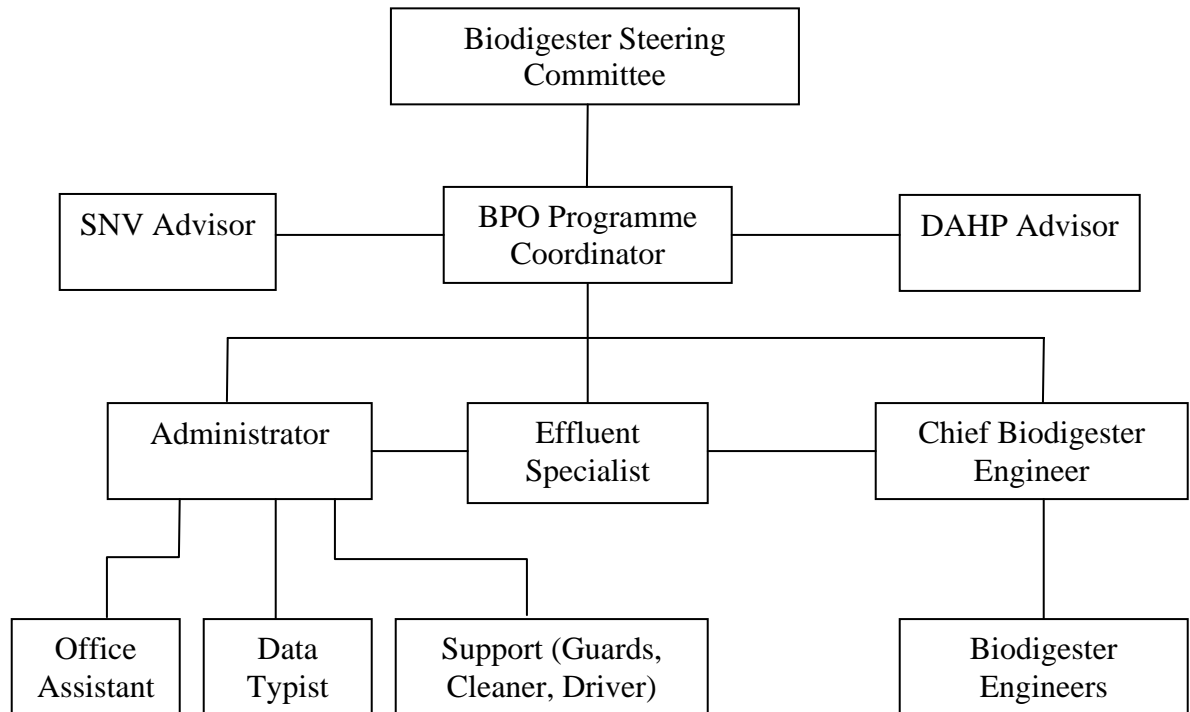

### 3.2.2 National Biodigester Steering Committee

The National Biodigester Steering Committee (NBSC) is foreseen to coordinate the activity planning of the BPO with the activities of involved line ministries and to monitor the results of the programme. The NBSC is currently being formed by MAFF and is expected to be in place at the time of the start of the programme.

The Committee will have 3 main roles: (1) advocacy of the programme within their respective organisations and with their (international) partners, (2) advice on policy matters and approval of work plans, and (3) progress monitoring and programme evaluation. The committee will meet at least twice a year and more often as the need arises.

The organisations represented should play an active role in the execution of the programme on a national level. The composition should represent a large section of the society while a bias towards a certain sector should be avoided. For the start of the programme the number of committee members can remain limited, 6 members would be largely sufficient. Organisations that can be invited are:

- The Ministry of Agriculture, Forestry and Fisheries (MAFF). Given the importance of MAFF for the programme as host organisation, the ministry could be represented with 2 persons. One being the chair of the committee while the second person acts as the focal point for the programme within the Ministry.

- DAHP. Although this Department is part of MAFF it is separately mentioned here because the department plays a key role at national level (advisory and coordination) as well as on the provincial level.
- NGO sector. NGO's will have to play an important role in the promotion and extension work and should therefore be represented in the committee. An organisation suitable to represent the sector is i.e. Catholic Relief Service Cambodia who has a number agricultural development programmes within the biodigester pilot area.
- Financial sector. Credit provision to potential biodigester farmers is an essential part of the programme. At the moment contact are established with Thaneakea Phum Cambodia Ltd (TPC) as credit provider. If TPC would indeed become the biodigester credit institution, they should be invited to participate in the committee.
- Women organisation. Women are the main benefactors of biodigester technology and main part of the promotion activities must be aimed at them. A (rural) women's interest organisation should be identified and invited to the committee. A possible candidate could be the Ministry for Women and Veterans Affairs.
- Private sector. No private companies have yet been identified as partner in the programme. Eventually this will have to happen and they must be represented in the committee.
- National Farmers Interest Organisation. Here we should look for an organisation that is in regular contact with cattle and pig farmers and can represent their interests. An organisation like 'Veterinaires sans Frontiers' (VSF) could be a possible candidate.

The members representing the respective organisations must be of a seniority that will enable them to represent the programme's interests at the highest level within their organisation.

### 3.2.3 Provincial Biodigester Programme Office

At provincial level, the ownership of the programme lies with the Provincial Department of Agriculture. The Director of this department will delegate the authority for the daily implementation of the programme to his Deputy Director in charge of the provincial department of Animal Health and Production. At this level the Provincial Biodigester Programme Office will be established.

The main activities and responsibilities of the PBPO are:

- Establishing annual and 6 month periodical plans and organise programme activities implementation upon approval;
- Cooperating with partner organisations in implementation of programme activities (bank, building contractor and/or mason teams, NGO's, households...);
- Promotional activities;
- Quality control on construction;
- Be responsible for results of the programme activities within province;

- Financial management for approved activities;
- Monitoring and evaluating programme activities and preparing annual and 6 monthly periodical reports for the NBPO.

The activities and responsibilities of the PBPO's are stipulated in the NBP provincial Guidelines, see annex III.

As with the NBPO, the provinces will be advised to and facilitated in the setting up of a Provincial Biodigester Steering Committee.

### 3.3 Implementation arrangements

#### 3.3.1 Conditions for implementation

For sound implementation the following conditions need to be fulfilled:

- The National Biodigester Steering Committee is considered an important element for the success of the programme. MAFF is in the process of establishing this committee and it should be in place at the start of the programme implementation.
- Both programme running funds and subsidy should be timely available.

#### 3.3.2 Reporting

Regular monthly progress and financial reports will be prepared on provincial level by the implementing agencies and submitted to the NBP office. Here these reports will be computed into national reports and submitted to MAFF and SNV on a monthly (financial) and quarterly (progress) basis in accordance with the prescribed formats.

#### 3.3.3 Monitoring

Monitoring of progress of the National Biodigester Programme is the responsibility of the National Steering Committee and the NBP office. Indicators for a successful implementation related to the specific objectives as formulated in chapter 2.2 are as follows:

**Table 8:** Indicators for a successful programme implementation

Specific Objective	Indicator
Installed number of biodigesters - number (17,500) - number of construction defaults	- minimum 75% achievement - maximum 10% as listed in the quality standards
Operation and Maintenance - failure rate ( no biogas use) - utilisation of digester capacity - female user training	- maximum 10% - average minimum 80% of daily required feeding - minimum 75% of users trained

<p>Maximising benefits</p> <ul style="list-style-type: none"> <li>- improved sanitation</li> <li>- saving on fuelwood</li> <li>- saving kerosene</li> <li>- use of effluent</li> </ul>	<ul style="list-style-type: none"> <li>- minimum of 50% of households use attached toilet</li> <li>- minimum 2000 kg /year per average household</li> <li>- minimum 50 litres/year per average household</li> <li>- minimum 70% of households use the digester's effluent as fertiliser</li> </ul>
<p>Capacity development</p> <ul style="list-style-type: none"> <li>- training of technicians</li> <li>- involvement of NGO's</li> <li>- training of managers</li> </ul>	<ul style="list-style-type: none"> <li>- minimum of 1000 masons and supervisors trained</li> <li>- NGO's active in 4 provinces in extension and promotion</li> <li>- 50 provincial department of agriculture managers/supervisors trained</li> </ul>

### 3.3.4 Evaluation

Two evaluations are planned in the course of the programme, a mid-term evaluation during the second year of operation to make recommendations about the second stage of 2 years and the final evaluation during the fourth year of the programme. The dates of the evaluations will be determined well in advance to allow the evaluations to be joint exercises between MAFF and SNV.

## **4. Programme benefits, assumptions and risks**

### 4.1 Gender

Based on the experiences with biodigester programmes in countries with similar socio-economical conditions in the rural areas it can be taken for granted that the implementation of the programme will reduce the workload of women in the participating households. Equally it will reduce the exposure of mainly women and children to smoke and indoor air pollution. Numerous studies of the domestic biodigester programmes in Nepal and Vietnam have documented the decrease in the workload of women caused by the introduction of biodigesters. The following activities are most affected: collection of fuelwood, collection of water, feeding of the plant, cooking and cleaning of cooking utensils. Besides feeding of the plant, especially when this is done with cattle dung, operation and maintenance of the plant hardly require additional labour.

Almost all women using biogas express great satisfaction with the cooking aspects of biogas. Biogas is quicker and easier for cooking than fuelwood. Moreover, a biogas flame is smokeless and does not require constant attention or blowing on the coals; women can put a on the burner and do other activities while the food is cooked. In summer, the heat during cooking is less. In general women feel that they cough less and have fewer problems with their eyes. There are reports however that the reduction of smoke and indoor air pollution leads also to an increase of mosquitoes.

Introduction of biodigesters does not necessarily change entrenched traditional patterns in the division of labour. Strategic gender needs are thus not specifically addressed by biodigester use. However, the reduction of workloads is to be considered as a pre-condition to make opportunities available for women to attend meetings, increase awareness, achieve literacy and gain financial security. Biodigesters do well to fulfil this pre-condition.

#### 4.2 Environmental aspects

Use of energy is only sustainable when it is an integral part of an ecological cycle. Burning of fuelwood, dung or agricultural waste, as is practiced in Cambodia (see chapter 1.2), is not sustainable when the use of fuelwood exceeds the production, resulting in deforestation and erosion. When agricultural waste and dung are burned soil nutrients are destroyed in the process.

Biogas on the other hand is a sustainable and renewable source of energy because it is part of a closed ecological cycle. The organic materials fed into the plant are used without being destroyed. The nutrients and organic matter (apart from carbon and hydrogen) will still be available in the effluent and can be returned to the soil. Burning of biogas does result in emission of CO<sub>2</sub> to the atmosphere but it does not contribute to the greenhouse effect because an equal amount of CO<sub>2</sub> is used by the plants in the ecological cycle. It is also for this reason that the nutrients are returned to the soil, plants will grow more abundantly and fix the CO<sub>2</sub>. Often pig manure is stored in ponds or discarded on to surface water. This not only leads to water pollution and foul smells, in this semi-anaerobic methane is formed and released in the atmosphere. Methane gas is a potent greenhouse gas, 21 times stronger than CO<sub>2</sub>. When the dung is digested in a biodigester the resulting methane is captured and burned. Furthermore, burning biogas is much cleaner than burning biomass in a simple stove. Apart from a biogas flame is smokeless (health aspect) it basically only emits CO<sub>2</sub> and H<sub>2</sub>O into the atmosphere whereas a simmering wood fire gives much more pollution.

The energetic payback period for a biodigester is short. With the simple construction materials that are used, such as bricks and cement, the main energy used for the construction of a biodigester is the fuelwood for making bricks. This energy is usually recovered within one year by a well functioning plant by the replacement of fuelwood.

At the end of the programme period, 16,625 biodigesters will be in operation (5% failure) producing annually about 10 million m<sup>3</sup> biogas and 250,000 tons of digested dung. The following environmental benefits are expected:

- Saving on traditional energy sources. When biogas is used for cooking it will save on fuelwood, agricultural waste and animal waste. One m<sup>3</sup> of biogas will replace about 5 kg of fuelwood or 9 kg agricultural waste or 10 kg of dung cakes. Assuming that 85% of all gas will be used for cooking and replacement will take place as per the shares of the energy balance 1995, the following amounts are expected to be substituted annually:
  - 42,500 ton of fuelwood (by 7.82 million m<sup>3</sup> biogas);
  - 3,825 ton of agricultural waste (by 425,000 m<sup>3</sup> biogas);
  - 2,550 ton of dung cakes (by 255,000 m<sup>3</sup> biogas).

The reduction on the emission of CO<sub>2</sub> will amount to 85,000 ton per year assuming that half of the dung fed into the plants will come from pigs.

The organic matter and plant nutrients of agricultural waste and dung cakes, which are otherwise burned, are available to sustain the fertility of the soil. Increased crop production, though difficult to quantify, will lead to absorption of CO<sub>2</sub> from the atmosphere.

- saving on fossil energy sources. When biogas is used for lighting it will save on kerosene. It is assumed that 15% of all gas (1.5 million m<sup>3</sup> per annum) will be used for this purpose. This will save 830,000 litres of kerosene per year (on average 50 litres per household per year).
- improving soil fertility. With the installation of a biodigester, the management of animal waste on the farm will improve. On a daily basis cattle and pig dung is collected and fed into the digester. If properly stored, treated and applied to the field, biodigester effluent has a higher fertiliser value than ordinary farm yard manure and can therefore increase the soil fertility. Besides possible savings on nutrients (NPK), the effluent contributes to sustain the the amount of organic matter in the soil. This matter plays a dominant role in nitrogen supply and, to a lesser extent, in phosphorus and micronutrient supply. Higher soil organic matter levels improve infiltration rates and water-holding capacity. This, in turn, has a positive effect on reducing soil erosion. Organic material can ameliorate the negative effect of low pH, as well as problems caused by having too coarse or too fine a texture. Additions of organic matter will break up surface crust, improve tillage after ploughing, serve as mulch to cushion soil from high intensive rainfall and provide a substrate in which micro-organisms can maintain high activity and thereby releasing nutrients tied up in the mineral soil. Despite its importance for the majority of the population, soil fertility in Cambodia is much less than in the neighbouring countries. This endangers the food security for the young and growing population.

#### 4.3 Poverty, employment and health

Although the early adopters of biodigester technology will most likely be the medium and larger farmers, smaller farmers too can be attracted to the programme. The flat rate subsidy policy favours smaller plant sizes and therefore smaller farmers more than larger ones.

The programme will seek cooperation with NGO's active in the agricultural sector with the specific objective to reach the smaller farmers. However, biodigesters will always need animal waste to be fed and will never benefit those without cattle and/or pigs and these are generally among the poorest of the society. Animal-less, landless and marginal farmers may benefit indirectly because of reduced pressure on the forest and greater availability of fuelwood. However, such a link is a lengthy and tenuous one.

The programme is expected to have significant health effects. The main positive effect is on the level of indoor air-pollution. Several studies of Asian households cooking on fuelwood have shown that exposure to woodsmoke, expressed in respirable suspended particulates (RSP), carbonmonoxide (CO) and formaldehyde (HCHO), is one of the major risk factors for

acute respiratory infections in infants and children. Replacement of open woodstoves with biogas stoves will lead to a considerable reduction of exposure levels to RSP and a significant effect on CO and HCHO concentrations.

Other effects include the fact that improved dung management leads to better hygienic circumstances. Toilet attachments will be promoted. The use of digester connected toilets not only improves the hygienic conditions in and around the farmyard but also offer privacy.

The programme generates a fair amount of employment for skilled as well as unskilled labour in rural areas. At the end of the pilot phase some 1500 masons and supervisors will be trained in the construction of biodigesters. At the same time 500 man-years will be required for the production of appliances and building materials while another 1200 man-years will be needed for unskilled labour during the construction of the biodigesters.

#### 4.4 Assumptions and risks

The programme runs a number of risks, some of which have been incorporated in the design of the programme while others remain outside the scope of the programme. Assumptions made in the design of the programme are spelled out in section 8.1 while section 8.2 indicates external risks.

##### 4.4.1 Assumptions

The technical potential for domestic biodigesters in the 6 selected provinces is estimated at 224,000 units but the effective demand is yet to be determined. Lack of marketing experience makes it difficult to arrive at reliable predictions about effective demand. A more detailed analysis, supplemented by data derived from a survey on willingness and ability to pay, will be needed to confirm provisional indications and conclusions as well as provide a more accurate estimate of effective demand. Such a study is planned to be undertaken in the first year of the programme.

Besides the effective demand is also no hard data on the availability of construction companies willing and able to build, maintain and repair biodigesters. Most of the registered construction companies are situated in the urban centres. There is very little information available on the type of construction companies established in the provinces.

Water harvesting, whereby water is stored in large cement jars, is common practice in Cambodia. In the past numerous artisans have been trained in jar making and have now established their own micro enterprises, often not registered as a company. These artisans have the basic knowledge to qualify for the biodigester mason training and are ideally situated in the villages.

If there are not enough registered construction companies available to satisfy the demand, self-employed artisans will be approached to form construction biodigester construction teams. In the long run these teams have to transform in full-fledged companies.

Provision of credit will be an important part of the programme. Although the biggest bank of Cambodia, Acleda, and the MFI Thaneaka Phum Cambodia have agreed to participate in the programme, the conditions for micro loans do not favour biodigester

farmers. The interest rates are high, between 3 – 4% per month and the maximum repayment period is 2 years. With the economical lifetime of a digester of 10 years, the repayment combined with the interest poses a heavy burden for the farmer over the first 2 years of plant ownership. At this moment the financial institutions are not willing to create a special product for biodigesters as this would interfere with their ongoing activities.

If the products on offer by the banking sector prove to be out of reach for a large part of the poorer farmers, with the help of (I)NGO's efforts will be made to organise farmer groups to facilitate the construction of biodigesters in batches. In this way farmers can support each other and save on cash expenditures. Poorer farmers will then also be able to profit from the programme.

#### 4.4.2 External risks

The climate in Southern Cambodia has shown erratic behaviour in recent years. Farmers have suffered from both drought as well as flooding in the same year. This not only affects the livelihood of the farmers, and therefore their capacity to invest in biodigesters, but also makes it technically difficult to construct plants.

## 5. Financial aspects

### 5.1 Financial analysis of an average biodigester

Given the distribution figures of the national cattle and pig herd over the rural households together with the gathering practices of dung and the climate, 6 m<sup>3</sup> will presumably be the most common plant size to be constructed over the programme period. With a feeding of 40 kg/day, such a plant will produce on average 1.6 m<sup>3</sup> gas per day. Given that not always all gas is used and for various reasons the plant might not be used every day the whole year round, the analysis is based on a 6 m<sup>3</sup> plant with a used gas production of 1.2 m<sup>3</sup>/day. Most families are now cooking on traditional 3 stone-ovens, meaning that the daily replacement value of the biogas amounts to 6 kg or 2190 kg/year.

Because the early deciders during the introduction of the technology will be the larger farmers who can take some financial risks, the first years the larger plants are expected to be more popular. Given the same, conservative, average daily fuelwood saving per day, the table below gives the estimated figures for all plant sizes per day and per year.

**Table 9:** daily and annual fuelwood savings per digester volume

Plant volume [m <sup>3</sup> ]	4	6	8	10
Daily minimum fuelwood savings [kg]	4	6	8	10
Annual minimum fuelwood savings [kg]	1460	2190	2920	3650

The basic data for the financial analysis are presented in table 10. The benefits associated with the use of biodigesters are derived essentially from the savings in expenditures from biomass fuels. This can be done because fuelwood is traded in every village. Prices vary from 200 to 300 Riel/kg (0.04-0.06 US\$/kg). The base price for fuelwood in the analysis is assumed to be 200 Riel/kg. The value of saved labour, improved health conditions and the recovered nutrients from bio-slurry are assumed to be zero because they do not yield an immediate financial return.

**Table 10:** basic data for financial analysis for a 6m3 plant

Costs	US\$		
Investment costs	350		
Ann maintenance costs	14	4 %	of investment costs
Subsidy	100		
Net cost	250		
Down payment	0		
Loan amount	250	36 %	Ann. Int. 2 years term
Ann loan payment			
Annual savings	Unit (kg)	US\$/unit	Total US\$
Biomass	2190	0.04	87.60

The base analysis indicates a financial internal rate of return (FIRR) of 23 %. Figure 1, below presents the results of a sensitivity analysis on the assumed price of fuelwood. The FIRR becomes negative when the price of fuelwood is below 0.025 US\$/kg and is 47 % at 0.10 US\$/kg.

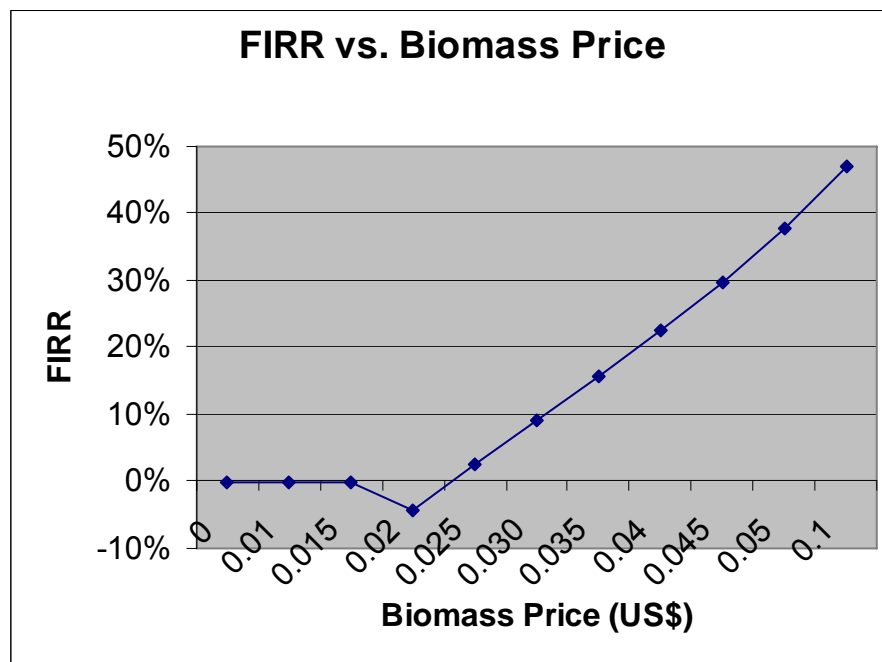

**Figure 1:** The Financial Internal Rate of Return (FIRR) depending on the price of firewood

A sensitivity analysis on the amount of the subsidy provided is presented in figure 2. The data indicate that the FIRR is not as sensitive to the percentage change in the level of the subsidy as it is to the price of fuelwood. The FIRR becomes less than 15 % when the subsidy is below 50 US\$ per plant and becomes 32 % when the subsidy reaches US\$140.00

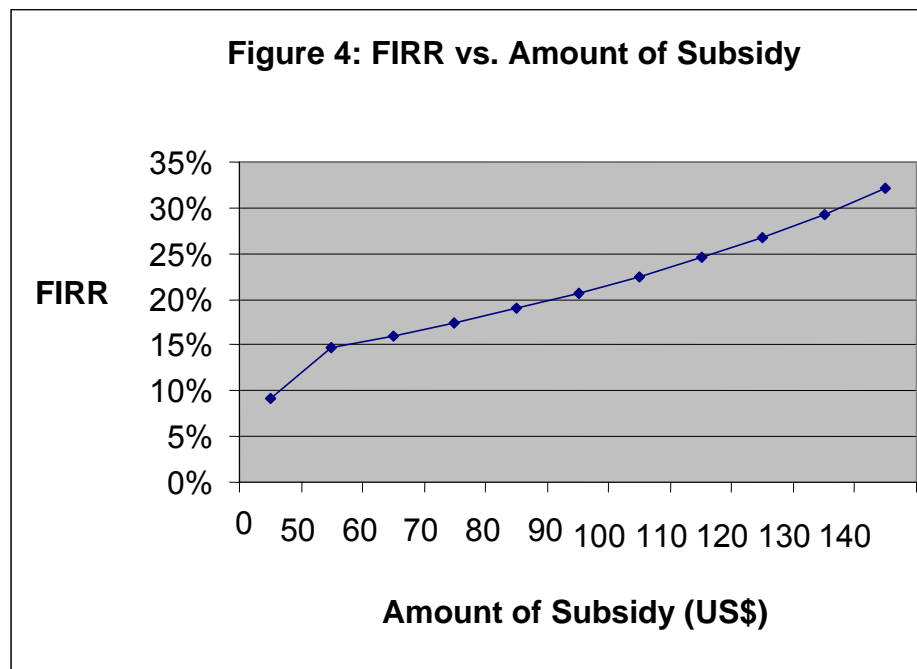

**Figure 2:** the Financial Internal Rate of Return depending on the subsidy level

When the same calculation is done for all plant volumes, the resulting FIRR is the following:

Plant size [m3]	4	6	8	10
FIRR [%]	12	23	30	32

## 5.2 Subsidy

Besides lowering the financial threshold for farmers who have the technical potential but little financial means the subsidy serves as an important promotion tool and provides a tool to safeguard quality standards on plant construction and after sales service.

An investment subsidy of US\$ 100 is considered sufficient to attract potential farmers while not being significantly excessive as to result in relative high FIRRs for the farmers. Here it has to be taken into consideration that the majority of the potential market consists of smaller farmers who will purchase 4 and 6m3 plants.

By providing a flat rate subsidy for all plant sizes the smaller farmers get percentage wise a higher subsidy on their investment while the administration is simplified.

## 5.3 Programme cost and financing

A cost breakdown by activity, expressed in US dollars, is presented in the table11 below. The costs of the programme as presented include a physical contingency of 5% but are excluding the capital input by farmers, through loans or from their own financial reserves, and the input in kind by MAFF. These inputs include a.o. accommodation at national and provincial level, cost of water and electricity.

**Table 11: Financial requirement**

<b>Programme Management</b>	2006	2007	2008	2009	Total
Programme Year	I	II	III	IV	
Estimated Production	1,000	3,000	5,500	8,000	17,500
No. of provinces involved	3	6	6	6	6
Subsidy Component (E 87.50/plant)*	87,500	262,500	481,250	700,000	1,531,250
Promotion & Marketing	14,000	20,000	25,000	25,000	84,000
Quality Control	6,500	8,000	12,000	12,000	38,500
R&D and Standardisation (incl. effluent)	33,500	30,000	30,000	30,000	123,500
Training	45,500	78,500	110,000	130,000	364,000
Monitoring and evaluation	12,500	15,000	15,000	15,000	57,500
Institutional Support	7,500	7,500	7,500	7,500	30,000
Programme Management National BO	142,000	150,000	150,000	150,000	592,000
Programme Management Provincial BO	22,500	45,000	45,000	45,000	157,500
External Evaluation	0	30,000	0	30,000	60,000
Unforeseen (approx. 5% excl. subsidy)	18,000	18,000	18,500	21,000	75,500
<b>Sub - Total in €</b>	<b>389,500</b>	<b>664,500</b>	<b>894,250</b>	<b>1,165,500</b>	<b>3,113,750</b>

<b>Technical Assistance</b>	2006	2007	2008	2009	Total
Programme Year	I	II	III	IV	
International TA SNV	136,000	141,440	147,098	152,982	577,520
National TA SNV starting 01/07/2006	12,750	26,520	27,581	28,684	95,535
Flex SNV Advisor Biogas, 3 months	34,000	35,360	36,775	38,246	144,380
Flex SNV Advisor Private Business					
Development	6,000	6,000	6,200	6,500	24,700
Audit	2,000	2,000	2,000	2,000	8,000
<b>Sub - Total Cost in Euro</b>	<b>190,750</b>	<b>211,320</b>	<b>219,654</b>	<b>228,412</b>	<b>850,135</b>

<b>Total Financial requirement</b>	2006	2007	2008	2009	Total
Programme Year	I				
Production	1,000	3,000	5,500	8,000	17,500
Farmer's contribution	208,000	624,000	1,144,000	1,664,000	3,640,000
Programme Cost	389,500	664,500	894,250	1,165,500	3,113,750
Technical Assistance	126,500	137,000	139,000	141,000	543,500
<b>Total Financial requirement in Euro</b>	<b>516,000</b>	<b>801,500</b>	<b>1,033,250</b>	<b>1,306,500</b>	<b>3,657,250</b>

\*Including a 5% bank fee

## List of References

- 1 Jan Lam, Willem Boers,  
Report on the feasibility study for a biodigester support programme in the Kingdom of Cambodia.  
January 2005
- 2 M. Leermakers,  
Extension of biogas: Strategies for implementation  
SNV-Nepal, January 1993
- 3 His Majesty's Government of Nepal, Netherlands Development Organisation (SNV),  
Biogas Support Programme Phase III proposal.  
February 1996
- 4 Dr. Amrit B. Karki et al,  
Biogas as a renewable source of energy in Nepal, theory and development.  
July 2005
- 5 Matthew S. Mendis, Wim J. van Nes,  
The Nepal biogas support programme: elements for success in rural household energy supply.  
July 1999
- 6 Vietnam Biogas Project Office  
Guidelines on implementation of project activities in provincial offices  
June 2004
- 7 Ministry of Industry, Mines and Energy  
Cambodia Energy Sector Strategy Paper (draft)  
2005
- 8 Websites:  
<http://countrystudies.us/cambodia/37.htm>  
[www.politicalresources.net/cambodia.htm](http://www.politicalresources.net/cambodia.htm)  
[www.cia.gov/cia/publications/factbook/geos/cb.html](http://www.cia.gov/cia/publications/factbook/geos/cb.html)  
<http://www.nis.gov.kh/SURVEYS/CDHS2000/AboutCDHS2001.htm>  
<http://www.asiasociety.org/publications/cambodia/rural.html>  
[http://hdr.undp.org/reports/global/2004/pdf/hdr04\\_HDI.pdf](http://hdr.undp.org/reports/global/2004/pdf/hdr04_HDI.pdf)  
<http://www.maff.gov.kh/structure.html>

## ANNEX I

BoQ 4m<sup>3</sup> Farmer's Friend Biodigester

SN	Item	Unit	Quantity	Unit Cost USD	Total Cost USD
<b>I Biogas Plant</b>					
1	Solid Brick	pcs	2000.00	0.03	50.00
2	Cement	bag	14.00	3.70	51.80
3	Gravel 1x2	m <sup>3</sup>	0.50	17.00	8.50
4	Coarse sand	m <sup>3</sup>	0.40	7.00	2.80
5	Fine sand	m <sup>3</sup>	1.10	9.00	9.90
6	Inlet PVC pipe 10cm dia, length 2m	piece	2.00	4.00	8.00
7	Iron bars ø 6	kg	10.00	0.50	5.00
8	Binding wire	kg	0.50	0.90	0.45
9	Paint Coat (Acrylic emulsion paint)	Lit	1.00	3.00	3.00
				<b>Subtotal 1</b>	<b>139.45</b>
<b>II Accessories</b>					
10	G.I, Gas outlet pipe Ø 0.5", 0.6m length with anchor and fitting elbow.	pcs	1.00	3.00	3.00
11	Cast iron nipple, Ø 0.5" for connection from 90° cast iron elbow to main gas valve	pcs	1.00	0.35	0.35
12	Main gas valve (Ball valve Ø 0.5")	pcs	1.00	1.70	1.70
13	Male-female socket Ø0.5", for connection from main gas valve to PVC. (PVC with aluminum thread).	pcs	1.00	0.45	0.45
14	PVC 90° elbow	pcs	4.00	0.12	0.48
15	T-socket Ø0.5" for water trap (thread in side)	pcs	1.00	0.40	0.40
16	Glue for PVC connection	bottle	1.00	0.70	0.70
17	Water drain	pcs	1.00	3.00	3.00
18	Gas tap	pcs	1.00	5.50	5.50
19	Teflon tape	pcs	1.00	0.25	0.25
20	Liquid gasket rubber	bottle	0.50	1.40	0.70
21	PVC piping system Ø0.5", elephant brand	m	10.00	1.30	13.00
22	Gas rubber hose pipe Ø 0.5"	m	1.00	0.40	0.40
23	Stoves with one burner	pcs	1.00	12.50	12.50
24	Lamp	pcs	1.00	5.00	5.00
				<b>Subtotal-II</b>	<b>47.43</b>
<b>III Labours</b>					
25	Skilled Labour	days	10.00	4.00	40.00
26	Unskilled Labour	days	18.00	1.50	27.00
				<b>Subtotal III</b>	<b>67.00</b>
				<b>Total</b>	<b>253.88</b>

## BoQ 6m<sup>3</sup> Farmer's Friend Biodigester

SN	Item	Unit	Quantity	Unit Cost USD	Total Cost USD
<b>I Construction Materials</b>					
1	Solid Brick	pcs	2400.00	0.03	60.00
2	Cement	bag	18.00	3.70	66.60
3	Gravel 1x2	m <sup>3</sup>	0.75	17.00	12.75
4	Coarse sand	m <sup>3</sup>	0.60	7.00	4.20
5	Fine sand	m <sup>3</sup>	1.20	9.00	10.80
6	Inlet PVC pipe 10cm dia, length 2m	piece	2.00	4.00	8.00
7	Iron bars ø 6	kg	12.00	0.50	6.00
8	Binding wire	kg	0.50	0.90	0.45
9	Paint Coat (Acrylic emulsion paint)	Lit	1.00	3.00	3.00
<b>Subtotal 1</b>					<b>171.80</b>
<b>II Accessories</b>					
10	G.I, Gas outlet pipe Ø 0.5", 0.6m length with anchore and fitting elbow.	pcs	1.00	3.00	3.00
11	Caste iron nipple, Ø 0.5" for connection from 90° cast iron elbow to main gas valve	pcs	1.00	0.35	0.35
12	Main gas valve (Ball valve Ø 0.5")	pcs	1.00	1.70	1.70
13	Male-female socket Ø0.5",for connection from main gas valve to PVC. (PVC with aluminum thread).	pcs	1.00	0.45	0.45
14	PVC 90° elbow	pcs	4.00	0.12	0.48
15	T-socket Ø0.5" for water trap (thread in side)	pcs	1.00	0.40	0.40
16	Glue for PVC connection	bottle	1.00	0.70	0.70
17	Water drain	pcs	1.00	3.00	3.00
18	Gas tap	pcs	1.00	5.50	5.50
19	Teflon tape	pcs	1.00	0.25	0.25
20	Liquid gasket rubber	bottle	0.50	1.40	0.70
21	PVC piping system Ø0.5", elephant brand	m	10.00	1.30	13.00
22	Gas rubber hose pipe Ø 0.5"	m	1.00	0.40	0.40
23	Stoves with one burner	pcs	1.00	12.50	12.50
24	Lamp	pcs	1.00	5.00	5.00
<b>Subtotal-II</b>					<b>47.43</b>
<b>III Labours</b>					
25	Skilled Labour	days	11.00	4.00	44.00
26	Unskilled Labour	days	20.00	1.50	30.00
<b>Subtotal III</b>					<b>74.00</b>
<b>Total</b>					<b>293.23</b>

## BoQ 8m<sup>3</sup> Farmer's Friend Biodigester

SN	Item	Unit	Quantity	Unit Cost USD	Total Cost USD
<b>I Biogas Plant</b>					
1	Solid Brick	pcs	2800.00	0.03	70.00
2	Cement	bag	22.00	3.70	81.40
3	Gravel 1x2	m <sup>3</sup>	0.90	17.00	15.30
4	Coarse sand	m <sup>3</sup>	0.80	7.00	5.60
5	Fine sand	m <sup>3</sup>	1.30	9.00	11.70
6	Inlet PVC pipe 10cm dia, length 2m	piece	2.00	4.00	8.00
7	Iron bars ø 6	kg	14.00	0.50	7.00
8	Binding wire	kg	0.50	0.90	0.45
9	Paint Coat (Acrylic emulsion paint)	Lit	1.00	3.00	3.00
				<b>Subtotal 1</b>	<b>202.45</b>
<b>II Accessories</b>					
10	G.I, Gas outlet pipe Ø 0.5", 0.6m length with anchore and fitting elbow.	pcs	1.00	3.00	3.00
11	Caste iron nipple, Ø 0.5" for connection from 90° cast iron elbow to main gas valve	pcs	1.00	0.35	0.35
12	Main gas valve (Ball valve Ø 0.5")	pcs	1.00	1.70	1.70
13	Male-female socket Ø0.5",for connection from main gas valve to PVC. (PVC with aluminum thread).	pcs	1.00	0.45	0.45
14	PVC 90° elbow	pcs	4.00	0.12	0.48
15	T-socket Ø0.5" for water trap (thread in side)	pcs	1.00	0.40	0.40
16	Glue for PVC connection	bottle	1.00	0.70	0.70
17	Water drain	pcs	1.00	3.00	3.00
18	Gas tape	pcs	1.00	5.50	11.00
19	Teflon tap	pcs	2.00	0.25	0.25
20	Liquid gasket rubber	bottle	0.50	1.40	0.70
21	PVC piping system Ø0.5", elephant brand	m	10.00	1.30	13.00
22	Gas rubber hose pipe Ø 0.5"	m	2.00	0.40	0.80
23	Stoves with one burner	pcs	2.00	12.50	25.50
24	Lamp	pcs	1.00	5.00	5.00
				<b>Subtotal-II</b>	<b>65.83</b>
<b>III Labours</b>					
25	Skilled Labour	days	13.00	4.00	52.00
26	Unskilled Labour	days	22.00	1.50	33.00
				<b>Subtotal III</b>	<b>85.00</b>
				<b>Total</b>	<b>353.28</b>

## BoQ 10m<sup>3</sup> Farmer's Friend Biodigester

SN	Item	Unit	Quantity	Unit Cost USD	Total Cost USD
<b>I Construction Materials</b>					
1	Solid Brick	pcs	3200.00	0.03	80.00
2	Cement	bag	26.00	3.70	96.20
3	Gravel 1x2	m <sup>3</sup>	1.15	17.00	19.55
4	Coarse sand	m <sup>3</sup>	1.00	7.00	7.00
5	Fine sand	m <sup>3</sup>	1.40	9.00	12.60
6	Inlet PVC pipe 10cm dia, length 2m	piece	2.00	4.00	8.00
7	Iron bars ø 6	kg	17.00	0.50	8.50
8	Binding wire	kg	0.50	0.90	0.45
9	Paint Coat (Acrylic emulsion paint)	Lit	1.25	3.00	3.75
<b>Subtotal 1</b>					<b>236.05</b>
<b>II Accessories</b>					
10	G.I, Gas outlet pipe Ø 0.5", 0.6m length with anchore and fitting elbow.	pcs	1.00	3.00	3.00
11	Caste iron nipple, Ø 0.5" for connection from 90° cast iron elbow to main gas valve	pcs	1.00	0.35	0.35
12	Main gas valve (Ball valve Ø 0.5")	pcs	1.00	1.70	1.70
13	Male-female socket Ø0.5",for connection from main gas valve to PVC. (PVC with aluminum thread).	pcs	1.00	0.45	0.45
14	PVC 90° elbow	pcs	4.00	0.12	0.48
15	T-socket Ø0.5" for water trap (thread in side)	pcs	1.00	0.40	0.40
16	Glue for PVC connection	bottle	1.00	0.70	0.70
17	Water drain	pcs	1.00	3.00	3.00
18	Gas tap	pcs	2.00	5.50	11.00
19	Teflon tape	pcs	1.00	0.25	0.25
20	Liquid gasket rubber	bottle	0.50	1.40	0.70
21	PVC piping system Ø0.5", elephant brand	m	10.00	1.30	13.00
22	Gas rubber hose pipe Ø 0.5"	m	1.00	0.40	0.40
23	Stoves with one burner	pcs	2.00	12.50	25.00
24	Lamp	pcs	1.00	5.00	5.00
<b>Subtotal-II</b>					<b>65.83</b>
<b>III Labour</b>					
25	Skilled Labour	days	15.00	4.00	60.00
26	Unskilled Labour	days	25	1.50	37.50
<b>Subtotal III</b>					<b>97.50</b>
<b>Total</b>					<b>399.38</b>

## Summary of Costs

Cost heading	Size of Plant in Cum and Cost of Installation in USD							
	4		6		8		10	
	Cost	%	Cost	%	Cost	%	Cost	%
Construction Materials	139	55	172	59	202	57	236	59
Appliances	47	19	47	16	66	19	66	16
Human Resources	67	26	74	25	85	24	98	24
<b>Total Cost</b>	<b>254</b>	<b>100</b>	<b>293</b>	<b>100</b>	<b>353</b>	<b>100</b>	<b>399</b>	<b>100</b>
Over head and guarantee	38		44		53		60	
<b>Grand Total Cost</b>	<b>292</b>		<b>337</b>		<b>406</b>		<b>459</b>	

Size in Cum	Tentative Cost in USD	
	Without Overhead and Guarantee	With Overhead and Guarantee
4	250	300
6	300	350
8	350	400
10	400	450



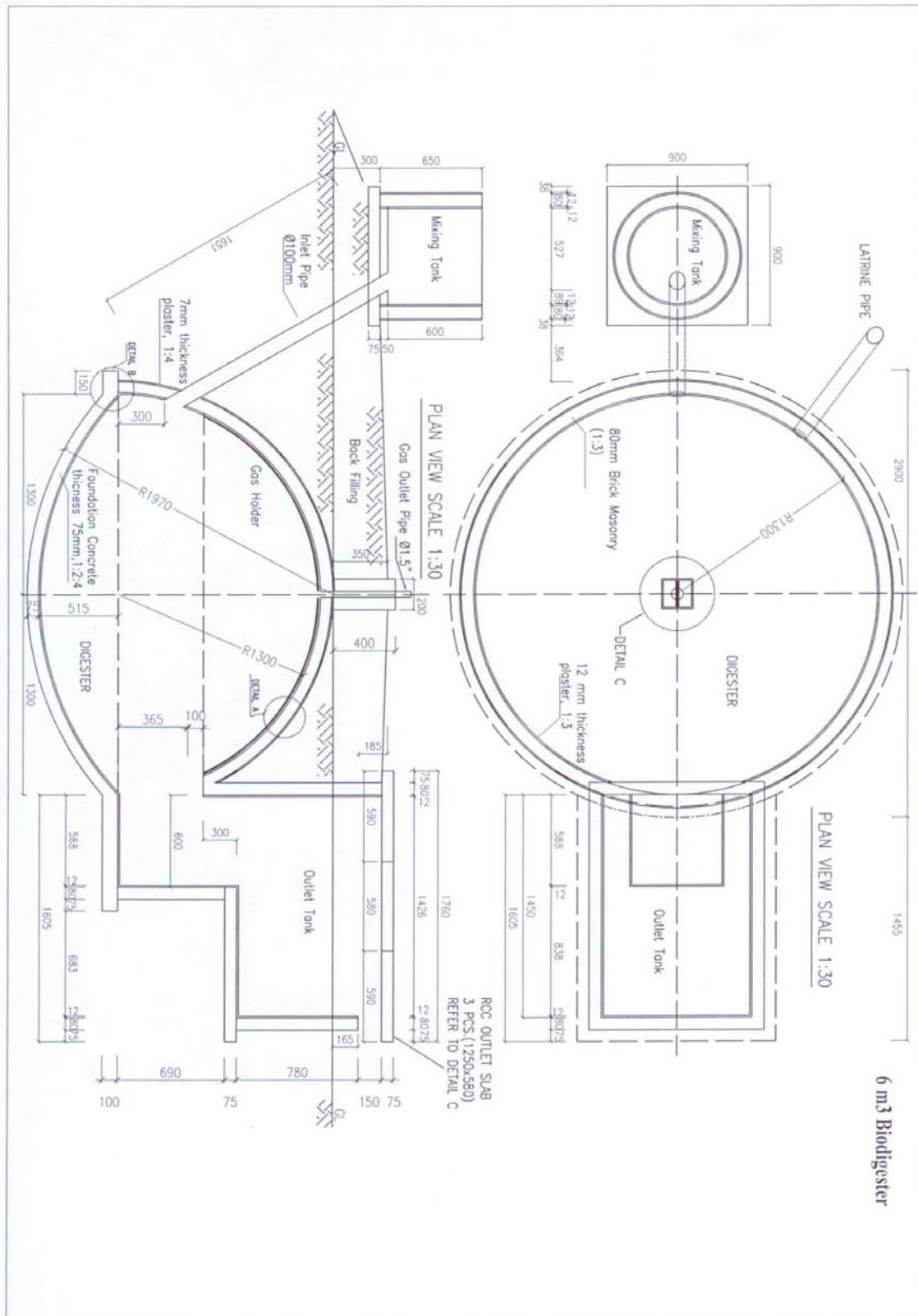

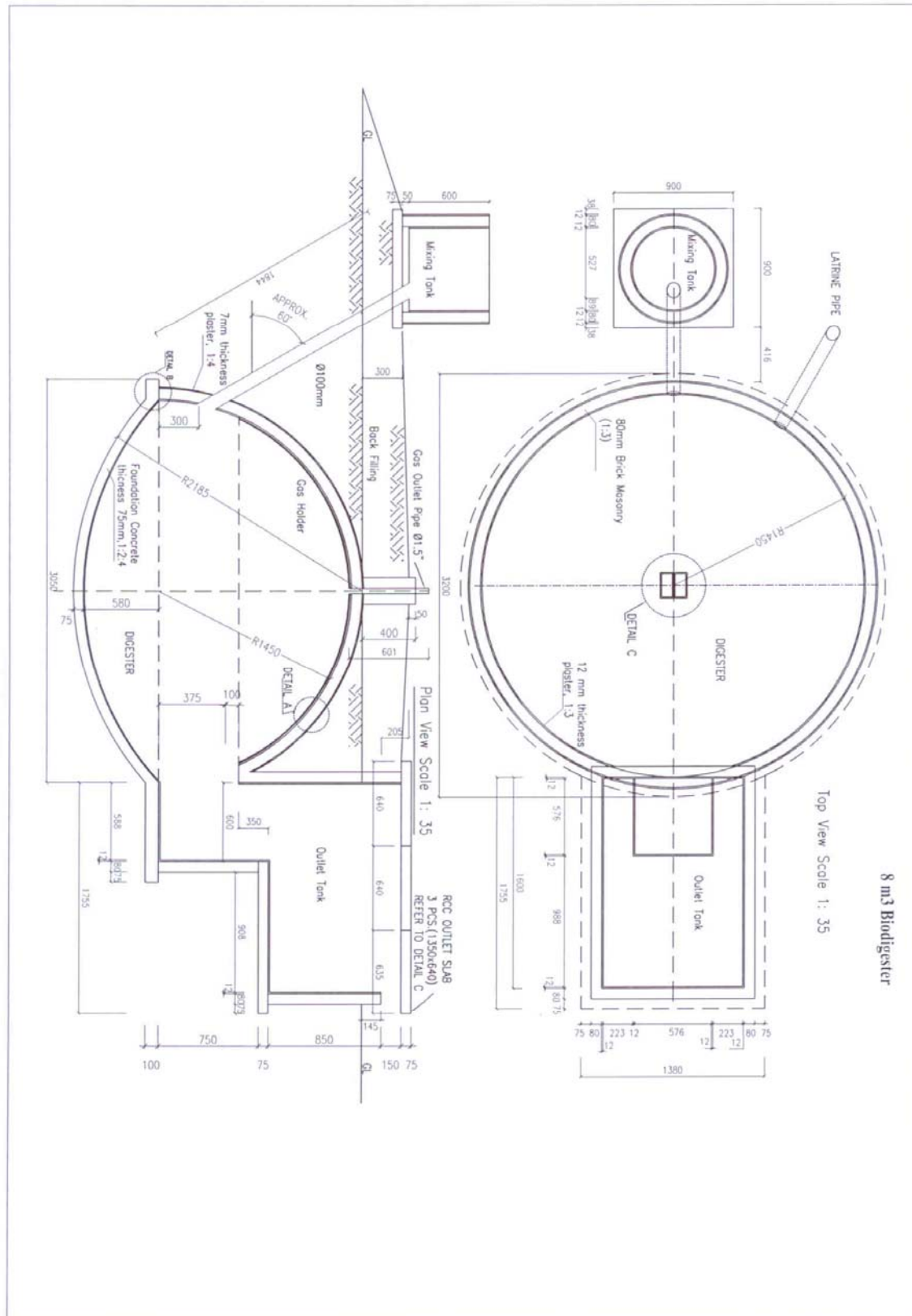



## Quality Standards for the Installation of Farmer's Friend Model of Biodigester – 2006

SN	Standards	Tolerances	Type of Default
	<i>Standards in Household, Size and Site Selection</i>		
1	One biodigester per household	Separate kitchen per biodigester.	Critical
2	Construction site not far from kitchen	Distance from kitchen not more than 20 meters.	Minor
3	Construction site not far from cattle shed or pig sty	Distance from cattle shed or pig sty not more than 20 meters.	Minor
4	Components of the biodigester adequately far from existing structures or trees	Plant components should be at least 2 m away from existing structure or trees.	Major
5	Enough space for biodigester construction as per drawing	Enough space to orient the plant location and slurry pits.	Major
6	Correct size of plant based upon the availability of feeding materials	At lease 5 kg of dung available per cubic meter capacity of biodigester.	Critical
	<i>Standards on Construction Materials and Appliances</i>		
7	Good quality bricks	Best quality locally available. Well baked, regular in size, free from cracks and broken parts.	Major
8	Good quality sand	Not contain more than 3% impurities as determined by bottle test.	Major
9	Good quality cement	Fresh, free from lumps, best locally available.	Major
10	Good quality aggregate	Aggregate should be angular, of regular size not more than 2 mm and free from dust or impurities.	Major
11	Good quality MS Rod	The MS rod should be free from heavy rust and at least 8 mm diameter.	Major
12	Good quality acrylic emulsion paint	It should be as approved by the quality control authority.	Major
13	Good quality inlet pipe	The inlet pipe should be of PVC, concrete or Polyethylene 10 cm diameter.	Major
14	Good quality water	Clean and free from organic matter and mud.	Major
15	Good quality dome gas pipe	The size should be bigger than 15 mm diameter with the elbow properly sealed in the workshop. Length should be 60 cm.	Major
16	Good quality main gas valve	As approved by the quality control authority.	Major
17	Good quality pipes and fittings	½" GI or 20 mm PVC pipe of best quality locally available.	Major
18	Good quality water drain	As approved by the quality control authority.	Major
19	Good quality gas tap	As approved by the quality control authority.	Major

## GUIDELINE ON IMPLEMENTATIONS of PROGRAMME ACTIVITIES IN PROVINCIAL OFFICES

20	Good quality connecting pipe	Either neoprene rubber hose or good quality plastic pipe as approved by the quality control authority.	Major
21	Good quality gas stove	As approved by the quality control authority.	Major
22	Good quality gas Lamp	As approved by the quality control authority.	Major
23	Good quality mixing devise??	As approved by the quality control authority.	Minor
	<b>Standards on Construction</b>		
24	Only trained masons carry out the construction work	The mason registered in PBPO office after completing training courses construction	Critical
25	Correct cement, sand, aggregate ratio	For all masonry works the ratio is 1:3 (cement:sand). For plastering works, 1:3 for inner surface and 1:4 for outer surface of the biodigester. Foundation concrete ratio: 1:2:4 (cement:sand:aggregate).	Major
26	Biodigester appropriately placed under the ground	The depth of digging as per drawing. It should not differ by $\pm 5$ cm from the standard. If because of high water table or rocky strata the depth is not adequate, proper justification to be provided. In this case stabilisation measures have to be provided around the structure.	Major
27	Correct diameter of the digester	The diameter of the completed biodigester should not differ by $\pm 1\%$ from the standard.	Major
28	Correct height of the curved bottom portion	The height should not differ by $\pm 2\%$ from the standard.	Major
29	Correct height of the position of the bottom of the inlet pipe	The height of bottom of the inlet pipe from the collar should not differ by $\pm 2$ cm from the standard.	Major
30	Correct height of the manhole	Height of manhole at the top of the curved opening should not differ by $\pm 2$ cm from the standard.	Major
31	Correct height – top of manhole to floor of outlet	The height between top of manhole to the floor of outlet should not differ by $\pm 2$ cm from the standard.	Major
32	Correct positioning of the dome gas pipe	The location of the dome gas pipe at centre. Max deviation 2% of the diameter of the digester.	Major
33	Proper plastering outside of the digester	The finished surface properly finished and smooth.	Major
34	Proper plastering inside the gas-holder	Gas holder treated with 5 layers of plastering as indicated in the construction manual. The finished surface smooth and free from cracks.	Critical
35	Plastering outside of digester and dome	The thickness of plaster should be 8 mm.	Minor
36	Proper back-filling in the outside of the wall of digester and gas holder	The space between natural soil and the digester wall filled with soils and compacted well. The height of back-filling at least 45 cm from the top of the dome.	Major
37	Proper length, breadth and height of outlet tank	The length, breadth and height of outlet tank should not differ by $\pm 2\%$ from the standard.	Major

## GUIDELINE ON IMPLEMENTATIONS of PROGRAMME ACTIVITIES IN PROVINCIAL OFFICES

38	Proper volume of outlet tank	The volume of outlet tank differs max. by $\pm 5\%$ from the standard.	Major
39	Proper plumb of the outlet walls	The plumb of the finished surface should not be more than $\pm 0.25$ cm 'in' or 'out'.	Major
40	Outlet floor properly finished	The floor is smooth, properly plastered and the level difference should differ by $\pm 0.2\%$ .	Minor
41	Properly casted outlet slabs	The thickness of the outlet slab should not differ by $\pm 0.05$ cm. The length and breadth of each panel should not differ by $\pm 0.2$ cm from the standard.	Major
42	Proper size of overflow opening	The length and height of overflow opening should not differ by $\pm 2$ cm from the standard.	Major
43	Correct positioning of outlet tank	The centre line of outlet, manhole, digester and inlet pipe in one straight line. The deviation max. $\pm 2$ cm.	Major
44	Proper backfilling against the outlet walls	The outside of the outlet walls properly compacted with rammed soil to prevent soil erosion.	Major
45	Correct height of inlet tank	The height of inlet tank should not differ by $\pm 5$ cm from the standard.	Major
46	Correct positioning of the inlet pipe	The inlet pipe placed at the near end to the digester so that inserting of pipe or pole is possible. It should discharge exactly at the hart line (imaginary line that joins centre of digester, manhole and outlet tank).	Major
47	Proper finishing works of inlet tank	The plaster surface smooth and free from cracks.	Major
48	Positioning of the inlet chamber	Floor of inlet chamber at least 15 cm higher than the bottom overflow opening in the outlet tank.	Major
49	Correct positioning of collection chamber for maturing pig manure	Pig manure and urine flow by gravity to the collection chamber.	Major
50	Positioning of the collection chamber	The floor of the collection chamber should be at least 15 cm higher than the bottom of overflow opening in the outlet tank.	Major
51	Correct positioning of inlet pipe from the latrine attached to biodigester	The inlet pipe should discharge within the location of 30% from the hart-line	Major
52	Correct positioning of the pan level	The pan level of the latrine at least 20 cm higher than the bottom of overflow opening in the outlet tank.	Major
53	Correct sizes of turret	The length, breadth and height (diameter in the case of circular turret) of the turret should not differ by $\pm 2$ cm from the standard.	Minor
54	Correct fitting of main gas valve	No fittings in between elbow in the dome gas pipe and the main valve. The joint is properly sealed with Teflon tape and good quality adhesive.	Critical
55	No unnecessary fittings in the pipeline	Pipeline contains a minimum of joints as. No unions used.	Major
56	Proper burial of pipeline	The pipeline should be buried to at least 30 cm	Major

## GUIDELINE ON IMPLEMENTATIONS of PROGRAMME ACTIVITIES IN PROVINCIAL OFFICES

		where possible. It should be protected well with clamps and covers where burial is not possible.	
57	Water drain able to drain the whole quantity of condensed water	The profile of pipeline should be maintained properly so that the whole quantity of accumulated water is easily drained.	Major
58	Water drain protected in a well maintained chamber	The size of the chamber should be such that it is easy to operate water drain and rain water does not enter into it. The pit should be provided with a good cover.	Major
59	Correct fitting of gas tap	The gas tap should be placed in convenient place and the joint should be sealed with Teflon tape and good adhesive.	Major
60	Correct fitting of gas stove	The connecting pipe from gas tap to the stove should be correctly fitted to avoid the gas leakage.	Major
61	Correct fitting of gas lamp	The gas lamp should be located in safe and convenient place. The joint should be sealed with Teflon tape and good adhesive.	Major
62	Proper construction of slurry composting pit	2 compost pits at least equal to the volume of biodigester to be constructed as per the standard dimensions	Major
63	User's instructed on operation and minor repair works	At least one member from the user's household should be provided with proper orientation on operation and minor maintenance of biodigester	Major
64	Provision of instruction book let	Instruction booklet should be provided to the users	Critical
65	Guarantee and After-sale-service provisions	Guarantee of 2 years in structural part and 1 on pipeline and appliances provided by the installer.	Critical

ANNEX III

MINISTRY OF AGRICULTURE FORESTRY AND  
FISHERIES

=====

SNV  
THE NETHERLANDS DEVELOPMENT  
ORGANISATION

=====

CAMBODIA NATIONAL BIODIGESTER PROGRAMME  
01/2006 - 12/2009

**DRAFT**  
**GUIDELINES**

ON IMPLEMENTATION of PROGRAMME ACTIVITIES IN PROVINCIAL  
OFFICES

PHNOM PENH - 01/2006

INTRODUCTION

-----

This provincial programme guideline is to guide the implementation activities of the biodigester programme in programme provinces, aimed at achieving a common consensus among programme stakeholders on:

- the execution of activities and ownership;
- supporting activities by the NBPO;
- procedures and reporting.

This guideline is developed in accordance with the MAFF and SNV agreed arrangements.

The above-mentioned contents will be the basis for the programme to be implemented smoothly and comprehensively within 6 provincial programme offices and between PBPO and NBPO.

The guideline includes:

Part 1 - Purpose of the Programme Guideline and Organisational Chart.

Part 2 - General background information

Part 3 - Implementation of Activities of PBPO

Part 4 - Financial Procedures and Expense Ceiling for PBPO

Annex A – Forms

Annex B – Sectoral standard – Domestic Biodigesters

-----

*Note:*

- Abbreviation:
- BPO: Biodigester Programme Office Phnom Penh
  - PBPO: Provincial Biodigester Programme Office
  - BS: Biodigester Supervisor
  - BM: Biodigester Mason

---

## PART 1

### Purpose of Programme Guideline and Organisational Chart

#### 1. Purpose:

- The Guidebook is to help programme officers and all related officers to understand the National Biodigester Programme and all management/implementation procedures of programme activities.

This guideline is to meet the following requirements:

- In compliance with regulations, principles and guidance of MAFF, the concerned Department of Agriculture as well as SNV.
- Approved by MAFF, Provincial authorities and SNV.

#### 2. Legal basis of the programme

- Memorandum of Understanding signed on 24-05-2005 by and between MAFF and Netherlands Development Organisation (SNV) on the implementation of the National Biodigester Programme in a selected programme area in Cambodia.  
*(The Provincial Guidelines will be an integral part of the National Biodigester Implementation Document and come into effect after the signing of the implementation arrangements between MAFF and SNV on this Document)*
- Some related documents such as programme documents, memorandum of understanding signed with partner organisation.

#### 3. Organisation

Organisational chart of the Programme Office is established within the framework of:

- Programme Feasibility Study of January 2005 and jointly approved by the Government of Cambodia and SNV in the Memorandum of Understanding signed on .
- Programme arrangements signed on .... by and between MAFF and SNV on the implementation of the National Biodigester Programme.

(a) A National Biodigester Programme Office (NBPO) was established within DAHP in collaboration with the SNV for managing, supervising, and monitoring (both operational and financial issues) and regulating its operations. The Programme Coordinator is assisted by a Senior Biodigester Advisor of SNV-Cambodia.

(b) At provincial level, each province has one PBPO hosted by the Provincial Department of Agriculture to arrange and implement programme activities within the provincial localities. These activities are:

- Establishing annual and 6 month periodical plans, and organise programme activities implementation upon approval.
- Cooperating with partner organisations in implementation of programme activities (bank, building contractor, NGO's, households...)
- Be responsible for results of the programme activities within province.
- Financial management for approved activities and be responsible for the balance of assigned finance.

- Monitoring and evaluating programme activities and preparing annual and 6 monthly periodical reports for BPO and functional organisations

Programme offices are located in Provincial Agricultural Departments and will use the stamp of the Department for all its transactions.

During operations, Provincial Steering Committees for managing the Provincial Biodigester Program consisting of the main stakeholders within the province will be established.

### ORGANISATION CHART NATIONAL BIODIGESTER PROGRAMME

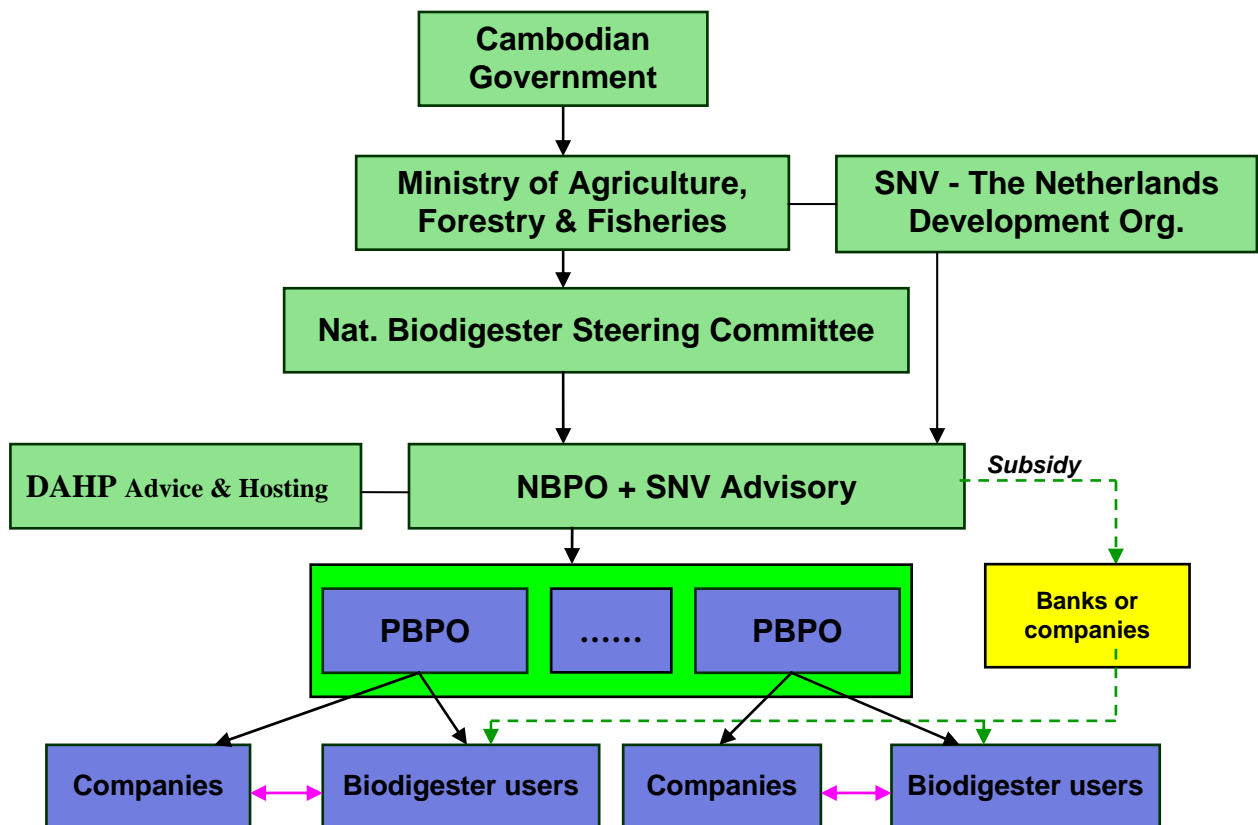

---

## PART 2

### *general background information*

#### **I. PROGRAMME OBJECTIVES**

##### **1. Overall Objective:**

The overall objective of the programme is to develop a commercial and structural deployment of biodigester technology, resulting in the reduction of biomass resource depletion and a significant improvement in the quality of life of the families concerned.

##### **2. Specific objectives:**

The specific objectives, contributing to the overall objectives, are:

- To develop a commercially viable and market oriented biodigester sector;
- To increase the number of family sized, quality biodigesters with 17,500 in selected provinces;
- To ensure the continued operation of all biodigesters installed under the biodigester programme;
- To maximise the benefits of the operated biodigesters, in particular the optimum use of digester effluent;
- Technical and promotional capacity development for further wide scale deployment of biodigester technology in Cambodia;
- To strengthen and facilitate establishment of institutions for the continued and sustained development of the biodigester sector.

#### **II. Programme implementing localities**

- The Programme will be implemented firstly in 6 provinces, namely Kampong Cham, Svay Rieng, Prey Veng, Kampong Speu, Takeo and Kandal.  
The programme can, with the consent of DAHP and SNV, included additional provinces on the condition that this does not alter the overall programme budget.
- Programme period: from January 2006 to December 2008.

#### **III. Technology alternatives:**

The financial analysis is based on the replacement value of fuelwood only during an economical lifetime of 10 years. The actual life expectation of the fixed dome biodigester is 20 years.

After considering several models for mass dissemination, the programme has chosen an adapted version of the Indian Deenbandhu plant. This new model, a brick made fixed dome with manhole through the outlet, will be called the 'Farmers Friend Biodigester.

The plant will be, at the start of the programme, available in 4 volumes: 4, 6, 8 and 10 m<sup>3</sup>. The range of volumes offered can change if demand requires do.

The table below lists the estimated costs for each plant volume, the feeding and gas production range.

Plant size	4 m <sup>3</sup>	6 m <sup>3</sup>	8 m <sup>3</sup>	10 m <sup>3</sup>
Estimated cost (US\$)*	225	300	350	400
Dung requirement (kg/day)	20 - 40	40 - 60	60 - 80	80 - 100
Gas production (m <sup>3</sup> /day)	0.8 - 1.6	1.6 - 2.4	2.4 - 3.2	3.2 - 4.0
Fuelwood saving (kg/day)	4 - 8	8 - 12	12 - 16	16 - 20

*\*)Costs need to be verified after plant design is finalised by the end of November 2005*

#### **IV Subsidy for biodigester users:**

- Subsidy rate in all provinces is the equivalent in Cambodian Riel of US\$ 100/household, not depending on size of digester.
- Subsidy will be transferred to the user through the bank or MFI if a biodigester loan has been taken or through the construction company for cash plants upon completion of the Handover/Acceptance Protocol for the biodigester plant.

#### **V. Biodigester Construction Companies**

Construction companies active in the provinces will be invited to become biodigester construction companies. Conditions to become such a company are:

- Company is registered with the local chamber of commerce and industry.
- Presence (permanent office) in the provinces where the construction will take place.
- Supervisors and masons trained by the BPO.
- Contractual agreements signed with the PBPO.

#### **VI. Mason teams for biodigesters**

- If it is not possible to establish enough local construction companies in provinces, PBPOs can build up mason teams of small size at district level. These mason teams will be managed by the PBPO's on biodigester quality and construction costs.
- Conditions to set up a biodigester mason team:
  - There exists at least one foreman trained and certified by the BPO.
  - Contractual agreements signed with PBPO.

#### **VII. Training activities**

All training activities of the BPO aim at improving knowledge on biodigester technology at different levels for: BPO biodigester engineers, biodigester supervisors and masons biodigester users, officers of partner organisations.

#### **VIII. Standards and quality control**

- Standards: the Programme will apply standards, including:
  1. General technical requirements
  2. Construction condition requirements
  3. Biodigester delivery and utilization requirements.
  4. Test and hand over standards.
  5. Operation and maintenance requirement.
  6. Safety requirement.

---

These standards will be developed in consultation with the parties involved and will, during the initial years, be fine-tuned on an annual basis.

- **Quality control:** The construction companies/mason teams have to follow the standard on construction requirements in their construction works. Biodigester supervisors of the PBPO will supervise the construction works of mason teams based on this standard and will certify quality of the plant upon completion. Each biodigester will be given a special code: PP.DD.CC/plant no. (PP: name of province, DD: name of district, CC: name of commune / plant no.: sequence number).

The first plants constructed by new mason teams or companies must all be inspected according to a quality control format and reported to the BPO. Of all plants constructed in the first year, at least 50% must be controlled for quality. Sample selection for control must be on a random basis.

#### **IX. Warranty and after sale service**

- Warranty duration for the construction work is 24 months since the hand over date. After sale service requires the biodigester company or mason teams to thoroughly monitor the plant upon plant owner's request and sign on Warranty Certificate granted to household by the company or team on hand over date.
- If the biodigesters have any trouble, and the company or mason team do not send a technician for trouble shooting or for operation instruction to household heads then household heads can inform PBPO by telephone or letter. As soon as the PBPO receive the information, this office must re-act immediately to the trouble.
- For every plant constructed, US\$ 10 will be deposited by the construction company or mason team on a special PBPO bank savings account. This amount, with interest, will be repaid to the company of mason team if there are no problems with the plant after the warranty period has expired. If the company or mason team does not execute any necessary repair work, PBPOs will use the deposit amount to repair the biodigester systems and will terminate the contract with that team.

#### **X. Activities on maximizing the benefits of the operated biodigesters**

- Maximizing the benefits of the operated biodigesters includes:
  - Further utilisation of biodigester slurry as fertilisers
  - Further utilisation of biodigester slurry as supplementary livestock foods (fish, pigs...)
- In order to maximize the benefits of the operated biodigesters effectively, it is necessary to build biodigesters as much as possible in clusters. This means a maximum number of plants in a given village at the same time. This will be more convenient for management, leader instructions and effect evaluation for effective extension.

#### **XI. Research and development**

Research and development activities will be focused on the following 3 points:

- Research to improve the existing biodigester model, including improving design, better materials, installation and construction technique, operation techniques, method to maximize the use of biodigesters and biodigester effluent in order to improve quality of biodigesters and cut costs.

- Research and build up biodigester development strategy including marketing and promotion and the support to companies.
- Measure and evaluate the effect of biodigester dissemination on individual households as well as on the communities.

## **XII. Monitoring and evaluation**

In order to assess the comprehensive effects of the Programme of all aspects (economical utilization of fossil fuel and fuel wood, keeping environment clean, improving community health, improving the ability to raise fund from household and loan from bank for biodigester development, awareness and demand for biodigesters, suitable development model for the next phase), it is necessary to develop forms for full information gathering. The information will be collected and classify as a database for analysis and comparison the effectiveness of the Programme.

Furthermore, on an annual basis a user survey needs to be conducted to get a clear view in the acceptance and appreciation of biodigesters from the user's perspective.

---

## PART 3

### Implementation of activities of PBPO

#### *Promotion and marketing activities*

#### 1. General Promotion

- Organise media programs on local radio, village information workshops, pre-construction trainings and involvement of others to introduce biodigester technology in their programmes/projects.
- Placard promotional posters and distribution of leaflets.

#### 2. Investigation for potential biodigester user

- Dung volumes depend on the animal type, weight of animal, feeding method and, most importantly, how animals are stabled and dung is collected. In order to have exact statistic, dung volume should be defined in cooperation with the animal owners.
- Dung volume can be estimated as per the following table:

Dung sources	Daily dung volume (kg/animal head)
Cows*	10-15
Buffaloes*	15-20
Pigs (adult)	4,0-6,0
Poultry	0,02-0,05
Human	0,18-0,34

- Dung volume collected in stables depends on confine time. If the animals are set free daytime on the fields, then the dung volume can be estimated of about 60% of the whole.

To verify the real availability of dung, it is recommended to gather and measure dung for several days before deciding on construction.

- Investigation for potential biodigester users: PBPO in cooperation with district agricultural extension network will carry out list of potential biodigester users per district order which will be basis for considering locations to implement programme as per the Statistical Form No. 1
- Criteria for selection of Programme locations:
  - Communes consisting of many villages and have potential biodigester users of more than 10 households/commune
  - Officers and households are enthusiastic with the application of biodigester technology.

The presence of NGO's active in agricultural and/or sanitation related activities is an advantage

---

### **3. Individual Promotion and marketing activities to potential biodigester users.**

- PBPO issues promotion documents to potential biodigester users, these documents will be made available by the BPO.
- Visits of biodigester plant models can be arranged wherever possible.

### **4. Registration for biodigester plant to Programme**

#### ***a. Conditions for households to be subsidised by the Programme***

- Have stable animal husbandry development of family size, with regular dung source of 15 ÷ 120 kg /day.
- There is enough space for a biodigester.
- Ready to cover expenses for construction of biodigesters and upgrade toilets, kitchens, breeding facilities, compost pits as a synchronous complex.
- Commit to cooperate with biodigester technicians to participate in biodigester trainings, supervising, testing, operating and maintaining the biodigester in accordance with programme technical requirements.

#### ***b. Approach to potential biodigester users for registration***

- Give further explanation to households regarding biodigester technology and programme assistance/support (technical assistance, subsidy of US\$ 100, construction of high quality digesters by experienced masons).
- Investigate if household conditions meet programme requirements then Investigation Sheet (Form 02) should be filled in.

#### ***c. Households sign construction contracts with mason teams***

- Programme officers recommend programme approved companies or mason teams to households for them to consider.
- Households sign construction contracts with company or mason team (Form 03).

### **5. Quality Control Activities.**

#### **5.1 Responsibility of Quality Control (QC) activities for Biodigesters.**

- Trained and certified PBPO Biodigester Supervisors (BSs) will be responsible for supervising, testing construction works, and other activities such as acceptance, operation and maintenance and after sale services.
- Trained and certified Companies or Biodigester Masons Teams (BMTs) will sign assignment contracts with the PBPO (Form 04) before starting their construction works and will be responsible for construction quality and after sale service within 24 months since the date of Acceptance.
- Users will be responsible for direct supervising, testing construction works and tightening of the whole plant system.

#### **5.2 QC activities on construction works of biodigesters.**

##### ***a. Training:***

- PBPO will select suitable and responsible Biodigester Supervisors and Biodigester Masons from that province for training.

- 
- BPO in cooperation with PBPO will organise trainings for BSs and BMs, provide them necessary background knowledge and skills on biodigester so that they can perform well programme activities. These activities will be largely contracted out to a recognised Training Institute (Preah Kossomak).

***b. BSs tasks in the construction:***

- Select suitable households to register with the Programme for technical and financial assistances.
- Help users select suitable designs and sizes, locations for biodigesters.
- If required, assist users in obtaining a biodigester construction loan with a recognised financial institution.
- Help users prepare materials and accessories, tools as per required technical standards for the biodigesters.
- Introduce trained and certified BMs to the users for their selections and construction agreements (Form 03).
- Help and provide document to users instructing construction supervising procedure in order to assure construction and installation quality.
- Supervise BCTs during construction and installation works in order to control construction quality. Any BMTs who violate seriously construction requirements will be reported to the PBPO's director for final solution or stop BM jobs, revoke certificates, cancel construction contracts and inform users.
- Instruct biodigester users to prepare feedstock as per quality requirements before operating plants.
- Instruct biodigester users on methods to apply feedstock and start up the biodigesters according to technical requirements.
- Carry out Test and Acceptance jobs in cooperation with users and BMs and sign Certificate of Acceptance (Form 05). The plant code will be mentioned in the Certificate of Acceptance for programme management. Plant codes are required as follows:  
PP-DD-CC/Plant No. per district.
- Register the plant into programme management file (form in database).
- Supervise, follow up, support Companies and BCTs, solve complains from biodigester users if required.

***c. BMs' tasks:***

- Construct biodigester plant and install accessories according to technical design and document requirements.
- Grant Certificate of Warranty to users (Form 06), and perform warranty responsibility as soon as there is any claims from users, visit and perform maintenance job at least once in six warranty months since the Acceptance date in order to assure plant quality which will be recorded into the Certificate of Warranty.

***d. PBPOs' tasks:***

- Establish the feedback information channel (contact point and telephone) so that the users can inform all troubles during operation and PBPO can help users to fix these in the soonest time. All these information will be recorded into the plant management file.
- Report to the BPO for release of subsidy funds.

---

### 5.3 Quality control activity

#### **a. QC activity purposes:**

- Detect incorrect activities for later modification in order to make sure all programme biodigesters are of good quality, users are satisfy with their plants and believe in the biodigester programme.
- Detect serious mistakes for claiming responsibility of the involving parties.
- **Person in charge:**
- PBPO Director, deputy director, provincial BSs, district BSs.
- BPO officers.

### 5.4 Quality control types:

#### *1. QC for the first batch of construction work:*

- *Area of QC: Plants constructed in a province (about 50% of total quantity/province)*
- *Quality Control under construction plants*
  - Done by provincial BS.
  - Scope of work: assist and check the construction, commissioning, Testing and Acceptance work. Make sure that the BMs are qualified enough to carry out their activities.
  - Form: QC under construction (Form 7a)
- *Quality Control completed plants.*
  - Done by provincial BS.
  - Scope of work: within a year after date of acceptance, district BS will check current operation status of the plant and check BM' warranty responsibilities.
  - Form: QC construction completed. (Form 7b)
- *Quality Control - Acceptance*
  - Done by provincial BS.
  - Area of work: whole plants of the balance batch construction work.
  - Scope of work: QC on plant quality for Acceptance.
  - QC form: Certificate of Acceptance (Form 06)

#### *II. Complaints*

- Done by provincial BS
- Area of work: all complaints from users which have not yet been solved by BMs.
- Scope of work: check current operation status of the plants and fix all troubles to have the plants working normal.
- QC form: QC completed plants (Form 7a)

---

## 5.5 Training

### 5.5.1 Training for Biodigester Supervisors:

Conditions: BSs must be technical officers of provincial agriculture extension, with a strong affinity for biodigester technology and very responsible in work, appointed by the province and trained and certified to be BSs by the programme.

#### *a. Training for new BSs:*

- Participants: provincial and district agricultural extension officers
- Training duration: 8 days
- Scheduled program:
  - + Theory: 03 days
  - + Practice: 04 days
  - + Opening & closing: 1 day.
- Training facilities and materials:
  - Training materials: prepared by BPO
  - Stationeries
  - Audio/video facilities for training
  - Facilities for practice: 3 under construction biodigesters at different stages
- Arrangement: BPO will be responsible for general training arrangements. PBPOs are responsible to send BSs to training courses.

#### *b. BS refresh training:*

- Participants: BSs who have attended the first BS training and are working actively for at least 6 months for PBPOs at provincial and district level.
- Training duration: 2 days
- Scheduled program:
  - + Theory: any supplementary/updated/upgraded document
  - + Experience exchange: PBPO experience reports + discuss
- Training facilities and materials:
  - Training materials are prepared by BPO together with PBPO reports.
  - Stationeries
  - Audio/video facilities for training
  - Facilities for practice: 3 under construction biodigesters at different stages
- Arrangement: BPO will be responsible for general training arrangements. PBPOs are responsible to send BSs to training courses.

### 5.5.2 Trainings for Biodigester Masons:

Experienced masons who are employed by a provincial construction company as well as experienced masons appointed by the PBPO as Construction Team Leaders and will commit to carry out all responsibilities as mentioned in the Article 2 of the Assignment Contract with Companies or Mason Teams (Form 04).

#### *a. Trainings for new BMs:*

- Participants: local experienced masons
- Training duration: 12 days

- 
- Scheduled program:
    - + Theory: 03 days
    - + Practice: 08 days
    - + Training opening & closing: 1 day.
  - Training facilities and materials:
    - Training materials: prepared by BPO
    - Stationeries
    - Audio/video facilities for training course
  - Facilities for practice:
    - 3 under construction biodigester plans at different stages
    - Construction tools for practicing

***b. Refresh training for experienced BMs***

- Participants: local experienced biodigester masons who are at least 6 months active.
- Training duration: 02 days
- Scheduled program:
  - Theory:
    - + provide updated knowledge.
    - + Experience exchanges.
- Training facilities and materials:
  - Training materials
  - Stationeries
  - Modern facilities for training room
- Arrangement: PBPO is responsible for organizing training courses for provincial masons with support from BPO.

**5.5.3 Training for biodigester users:**

***a. Training for biodigester user before construction work:***

- Participants: biodigester household members who directly operate and maintain biodigesters daily
- Training duration: 1 day
- Scheduled program:
  - + Introduction to biodigesters: 0,5 day
  - + Discussion: 0,5 day
- Training facilities and materials:
  - Training materials: prepared by BPO.
  - Audio/video facilities.
- Arrangement: PBPO will be responsible for organising trainings for users at villages and inter-village level.

***b. Training for biodigester user after construction work:***

- Participants: biodigester owner after sometimes of plant operation
- Training duration: 1 day
- Scheduled program:

- 
- + Information update: 0,5 day
  - + Discussion: 0,5 day
  - Training facilities and materials:
    - Training materials: prepared by BPO.
    - Audio/video facilities
  - Arrangement: PBPO will be responsible for organize trainings for users at villages and inter-village level.

#### **5.5.4 Training for bank officers, related Government and Non-Government Organisations**

- Participants: bank officers, authority officers, health care officers, representatives of the NGO's such as VSF and CRS, Women's Organisations...
- Training duration: 1 day
- Scheduled program:
  - + Introduction to biodigesters: 0,5 day
  - + Discussion: 0,5 day
- Training facilities and materials:
  - Training materials: prepared by BPO
  - Audio/video facilities
- Arrangement: PBPO will be responsible for organisation provincial and district level.

#### **6. Quarterly activity report regime:**

- PBPOs have to send Quarterly activity report as per Form 09 to BPO on every 10<sup>th</sup> day of the next quarter as the latest.
- Within 2 weeks after completion of Biodigester Mason training, PBPO report biodigester mason training list to BPO as per Form 9.

---

## Part 4

### Financial procedure and allowance ceiling for pbpo

*This chapter needs to be discussed with MAFF and SNV financial administrators*

#### I. budgets, plans and reports

##### 1. Prepare quarterly and annually plan/budget:

- Quarterly financial plans include activity plans and budget prepared by PBPOs. BPO will cooperate with PBPOs in setting detail activities for every quarter and for the whole year from which PBPOs can establish its own activity plans to meet proposed target.
- Quarterly financial plans should include activities from the previous quarter which have not yet completed or paid (if any).
- Quarterly financial plans will be established by PBPOs, and will be considered and may be revised by BPO.
- Final approved quarterly financial plan will be the basis for all PBPO activities and expenses during that quarter.
- Approved quarterly financial plan must be very specific and detail, and should show all activities and expenses based on general budget structure of BPO.
- Approved quarterly financial plan may vary from general programme budget.
- Any actual expenses on budget-lines which are different with approved budget lines will require written approval from Programme Coordinator of BPO, otherwise payment will not be settled.
- PBPO Quarterly financial plan (Form ..) should be sent to BPO by the 20<sup>th</sup> day of the last month of the previous quarter, and PBPO Yearly Budget should be prepared and sent to BPO in August of the previous year. Based on these, BPO will finalize in September, which will be basis for Budget and Activity Plan Proposal to be submitted to MAFF and SNV in October.

##### 2. Programme budget

- Programme budget is approved in detail amount based on expense items.
- Programme budget will be basis for quarterly activity and financial plan.

##### 3. Reporting

- Progress reports, mid-term/summary reports must be based on Activity Report. Reports should be consistent in all technical and financial data which PBPOs should follow.  
On every 10<sup>th</sup> day monthly, PBPO accountants will have to send financial reports to BPO so that BPO accountant can prepare general accounting report. All PBPO reports require stamp and signature of PBPO accountant, chiefs/deputy chiefs.
- PBPO Reports on monthly expense will be compared with quarterly financial plans and budget of that month.
- Quarterly/annual reports for expenses within that quarter/half year/full year in comparison with PBPO plans and budgets will be sent to BPO in the 10<sup>th</sup> day of the next quarter/half year/full year.

##### 4. Accountants

- PBPO accountants should keep in file programme agreements, programme budget plans, quarterly plans approved by BPO as well as all approved changes in quarterly plans.

---

## **II. BANK TRANSFERS FROM BPO**

- Transferring money for quarterly expenses are based on reports of previous quarters and approved activity plans of on going quarters.
- PBPO activity plans of the next quarters should be submitted to BPO by end of the previous quarters for approval then BPO will transfer money to PBPO account.

## **III. PBPOS' OPERATION - BANK BOOK:**

### **1. Bank accounts**

- PBPO bank accounts will be opened at provincial ACLEDA banks.
- These bank accounts are for PBPO activities only and account holders will be deputy directors of PBPOs.

### **2. Reconcile**

- Reconcile aims at double-check data from all related sources in order to find and correct any wrong entries if any.
- Bank reconcile aim to double check opening, closing and transactions between bank book and bank statement. These data must include balance data by month end as well as all coming data.
- Monthly reconcile activities for detail balance of deposit accounts will be done by early of the next months. Latest deadline for these activities are the 10<sup>th</sup> day monthly.
- PBPO accountants, based on data of bank account statements, must do reconcile activities and prepare reconcile reports (Form... ) with signature of PBPO Deputy Director. These reports must show monthly balances as stated in the bankbooks of PBPOs (Form ...), in the account bank statements, and differences in these two balances, with reasons (if any).

### **3. Bank interests**

- Bank interests for cash deposits will be booked as income.

### **4. Cheques**

- PBPO accounts must have separate cheque books.
- All  $\geq$  US\$500 payments must be made by cheques or by bank transfer instead of cash.
- All cancelled cheques must be kept in cheque books.

### **5. Book entry activities**

- When booking all payment vouchers, besides supporting documents, ref. number of bank statements, cheque numbers, bank transfer numbers also must be mentioned.

## **IV. BIODIGESTER COMPANY DEPOSIT - BANK BOOK**

### **1. Bank accounts**

- Biodigester Companies or Mason Teams will deposit US\$10 on every plant constructed. A deposit account will be opened at provincial ACLEDA (These accounts can not be opened under personal name of representative of PBPO).
- These bank accounts are used for as a guarantee on the plant's warranty. Account holders will only be PBPO deputy directors.

---

## 2. Reconcile

- Reconcile aims at double-check data from all related sources in order to find and correct any wrong entries if any.
- Mason Deposit - Bank book reconcile aim to double check opening, closing and transactions between bank book and bank statement. These data must include balance data by month end as well as all coming data.
- Monthly reconcile activities for detail balance of deposit accounts will be done by early of the next months. Latest deadline for these activities are the 10<sup>th</sup> day monthly.

## 3. Bank interests

- Bank interests for cash deposits will be booked as income.

## 4. Cheques

- All cancelled cheques must be kept in cheque books.

## V. CASH

### 1. Purpose

- Cash fund of PBPO will be used for biodigester activities only.

### 2. Storage

- PBPO should arrange separate safe for cash of PBPO.
- If it is impossible to arrange separate safe for PBPO's cash, PBPO accountants can share safe. And cash of PBPO will be putting in separate locked safety boxes or locked boxes which are put inside that safe. Cashiers of provincial offices keep safe keys while programme accountants keep the inside shelve/box keys.
- PBPO accountants do not keep PBPO cash in hand. Every programme members can only keep PBPO cash as advance payments.
- Receipts must prove all increase/decrease in PBPO accounts.

### 3. Payment amounts

- PBPOs must minimize of payments in cash instead of bank transfers or cheques.
- PBPO accountants must keep cash at bank. Only cash equivalent of US\$ 500 maximum can be kept in safety boxes of PBPOs.
- Any demands for bigger amounts (more than approved maximum amount of US\$ 400) will be planned in advance regarding time and quantity. Withdrawals will be made closely to the need time in order to minimize cash amount while PBPO activities still can be done timely.

### 4. Cash count and reconcile

- PBPO cash count will be done by end of ending day of months. There are at least accountants and deputy directors of PBPOs participating in ash count activities. Results of cash count must be made in written (Minute of Cash count) and signed by participants.
- Reconcile activities aim at double-checking data from two or more sources in order to find out and correct all mistakes from one or more sources if any. Reconcile activities for cash aim at double-checking data between cash amounts and cashbooks. These checking must

---

be done every beginning of month for balance and activities of the previous month. Deadline for these activities are the 10<sup>th</sup> day monthly.

## **V. Accounting books**

### **1. Basic accounting books**

#### **Cashbook:**

- Cash books must show in/out/ coming and balancing cash
- Basis for recording book keeping into cash books are payment vouchers

#### **Bank book**

- Bank books will record all increase/decrease cash in bank account balances, include bank interests and bank charges.
- Basis for recording/book keeping transactions into bankbooks are payment vouchers, debit/credit notes from bank (include monthly bank interests and bank charges), cheques, bank transfers /payment orders.

#### **Expense Books**

- Expense books record all expenses which are structured according to programme budget plan.
- Basis for posting transactions into expense books are expense receipts

#### **Book keeping**

- Book keeping includes preparation of payment vouchers and account entries, which are to be done immediately when transactions happen.
- All information recorded in account books must be in details such as: dates of entries, dates of payment vouchers, codes, contents.
- By end of month, accountants must total by columns and accounts in every books.
- Expenses should be booked according to activity codes & budget items in order to prepare finance reports and compare with budget easily.

#### **Opening book**

- When opening books are done, deputy directors of PBPOs will sign, stamp and date on every first pages.
- All pages of the new books will have to stamp to combine all pages of the book.

## **VI. Payment vouchers, supporting document**

### **1. Payment vouchers, supporting document**

- Payment vouchers include recorded vouchers and supporting documents.
- Payment vouchers should show in details following information: account code, payment voucher no./ref. (must be in sequence as instructed in the Item III), dates, and names of recipients, payment descriptions, total amounts, and signatures.
- Supporting documents should include basic information such as: date, names of recipients, addresses, payment descriptions, total amounts, signatures.
- All information on payment vouchers must be clear and true.
- Payment vouchers, bank transfers, cheques (new cheques, cheque stubs, canceled cheques), invoice, good receipt notes,, bank statements (include books, lists of bank

---

interests, bank charges), lists of staffs' working day, quotations, contracts... are payment documents.

- Accounting document are include: account books, finance plans, finance reports, legal documents such as new account registered documents, signature samples...
- All payment vouchers must be original and show actual payment in terms of payment contents, dates, and values...

## **2. Filings**

- All payment vouchers, accounting documents of PBPOs must be filed in separation with other document.
- All payment vouchers, accounting documents of PBPO must be filed in time and order sequences of either cash or bank transfer type for each year operation,
- All proved documents must be attached with payment vouchers instead of putting outside.
- All written payment vouchers or cheques, which are canceled, must be kept in payment voucher/cheque books.
- Period for filing these accounting documents must follow government's regulation of at least 5 years.

## **VII. PAYMENTS**

### **1. Mode of payment:**

- Modes of payment for PBPO' expenses are: (Risks of payments are increased in the following sequences) 1. Bank transfer (payment orders / cheques), 2. Cash, 3. Advance then use that advance to make payment.
- In this regard, case by case, the least risk of payment will be applied.

### **2. Procedure for request a payment**

- PBPO staffs prepare payment requests when any payment demands arise, attach with proved documents (invoices, receipts...). Payment requests must show modes of payment (cash, cheques, payment voucher)
- Deputy directors of PBPOs will sign payment requests upon checking its reasonability and properly.
- Accountants will settle payments after considering reasonability and properly of payment requests.

### **3. Payment procedures**

- Accountants will write on 3 copies of payment vouchers (or cheques if payment made by cheques, or payment orders if payment made by bank transfers), and attach all proved document for PBPO deputy director to sign.
- After PBPO deputy directors has been signed, the 3rd copy will be kept in the payment voucher books, the 2nd copy will be given to recipients, and the 1st (original) will be signed by the recipients and will be filed together with proved document.
- Accountants will record payments based on information as shown in the 1<sup>st</sup> copy which has been signed and attached with proved document.

### **4. Payment approvals**

- All payment requests such as payment vouchers, cheques much get signatures of PBPO deputy directors and programme accountants.

## **II. Expenses**

### **1. Regulation on expenses**

- PBPO deputy directors have to keep programme budget and approved quarterly finance plans in order to make sure properly of expenses.
- All expenses must be in accordance with quarterly finance plans approved by BPO in terms of descriptions as well as allocations (See X. Ceiling budget). Quarterly finance plans are the only basis for office activities and expenses, while programme budgets are for activity orientation only.
- All expenses which are different to approved quarterly finance plans must be approved in written by BPO in advance.
- All expenses must be correct to actual expenses even these amounts are less than BPO approved amounts.

### **2. Some particular expenses and activities**

#### **Fixed expenses for office operation**

- BPO and PBPOs will sign contracts on fixed monthly expenses for PBPO office operations. (See Ceiling budget)

#### **Payment in cash or in goods**

- When any demands on payments in cash or in goods (to households, trainees, programme members...), it is necessary to list out recipient names, detail cash amounts or types of kinds, signatures of recipients, dates of receipt, descriptions and purposes of payment.

#### **Budgeted expenses**

- All budgeted expenses such as training fees for trainers, supervisor fees must attach with working time lists mention in detail times, venues, and participants confirmed by deputy directors of PBPOs.

**X. Ceiling budget**

**1. Expense for PBPO operation activities**

**Monthly fixed expense**

*Ceiling budget for province with no motobike*

*Ceiling budget for province with motobike*

Description	Unit	Quantity Per month	Unit price	Total US\$	Official Invoice
<b>Office operation expenses</b>					
Telephone charge	Call	30			No
Fax charge	Send	10			No
Internet charge	Hour	15			No
Stationery	Set	1			No
<b>Total office operation expenses</b>					
<b>Transport allowance</b>					
Motorbike allowance	Day	22			No
Petrol and maintenance allowance	Day	22			No
	<b>Unit</b>	<b>Quantity</b>	<b>Ceiling</b>	<b>Total</b>	<b>Official</b>
<b><u>Un expected expenses</u></b>		<b>Per month</b>	<b>Budget</b>	<b>US\$</b>	<b>Invoice</b>
Field trip allowance	Day	30			No
Accommodation		10			Yes

**2. Ceiling budget for provincial training courses, seminars**

**3. Ceiling budget for biodigester market survey:**

- Biodigester market survey and marketing activities:

**3. Ceiling budget for quality monitoring:**

- Biodigester plant testing and acceptance activities: US\$ 10 /plant
- Biodigester plant construction supervision: 15 US\$ /plant



PBPO PROVINCE.....

**Form 02**

**BIODIGESTER PROGRAMME**  
**Survey form on potential households**

Code No.....

*General Information*

Province: .....; District: .....; Commune: .....; Village: .....

Name of household head: ..... Telephone No: .....

Number of people in family: Adult:  Children (age <  To

Date of survey .....

*Land information*

Total land area: ..... m<sup>2</sup> Land area for biodigester: ..... m<sup>2</sup>

Groundwater level in dry season .....m Flooding problems in wet season: yes / no

**WATER AND SANITATION INFORMATION**

Sanitary works		Running water sources		General sanitary			
Simple Pit latrine		River			Good	Fair	Bad
Improved latrine		Lake/Pond		Kitchen			
No latrine		Deep Tube well		Latrine			
Drainage system		Shallow Tube well		Water Source			
		Dug-wells		Drainage System			
		Piped Water Tap		Household wastes disposal			
		Canal					

*Animal husbandry development activities*

Number of domestic animals:

Animal Type	Pig		Cattle		Buffalo	
	Adult	Calf	Adult	Calf	Adult	Calf
Quantity						

Daily dung volume: ..... kg/day

*Credit demand*

How much do you want to loan from a bank to build biodigester:

..... Thousand Riel

Do you owe a bank? : Yes:  No:

**Survey officer**  
 (Full name and signature)

**Biodigester Household head**  
 (signature)

PBPO Province .....

**Form 03**

No.: .....<sup>2</sup>

### CONTRACT ON BIODIGESTER CONSTRUCTION

- Pursuant to approved document dated ..... of the Government on approval for the National Biodigester Programme
- Pursuant to the Programme Provincial Guidelines on the National Biodigester Programme

**1. Party A: Biodigester Programme supported household.....**

Address: ..... Telephone:.....

Household Owner: .....

**2. Party B: Biodigester Mason Team.**

Address: ..... Telephone:.....

Representative by: ..... Title: Team Leader

**3. Both Parties agree to participate in construction work of biodigester programme upon the following commitment:**

**Article 1. Scope of work:**

- To construct biodigester size ..... m<sup>3</sup> at Party A's house area.

**Article 2. Obligations:**

**Party A:**

- + Give biodigester design approved by the Programme, prepare location, material and equipment according to quality and quantity requirements of the programme, and set deadline for construction works to Party B.
- + Put the plant into operation and prepare for Acceptance in 30 days as the latest after the completion date.
- + Pay for construction work as agreed in the Article 3

**Party B:**

- + Carry out construction work according to designed model, quality and quantity and set time as stipulated in Article 4.
- + Be responsible for safety at work, and bear all expenses if any accident happens.
- + Warranty construction works within 24 months since the Acceptance Date in case Party A operates and maintains the biodigesters correctly to programme requirements

---

<sup>2</sup> Contract Number is in district sequence

---

**Article 3. Price and Payment:**

- + Total contract value is:  
(in number) ..... Riel, (in words:) ..... Riel.
- + Party A will pay 100% of the total contract value to Party B within 07 days since acceptance date. Beyond that period, Party A will be fined 1% of total contract value for each day of late payment

**Article 4. Construction completion date**

Date .....month ..... 200 ... at the latest.

**Article 5. Unilateral Termination of construction contract and compensation:**

- + Each party has right to terminate the construction contract unilaterally and can request for compensation when the other party offend contract provisions.
- + The offending party has to compensate all expenses which the other party had paid for the lost, unless otherwise stated.

**Article 6. Complain and dispute settlement:**

All complains and disputes will be considered and settled by both parties base on mutual interest. If both parties can not reach final agreement then the matter will be brought before Civil Court for final.

This contract is made on date... month... year 200... in 3 copies of the same value and become effective since the signing date.

**FOR HOUSEHOLD (PARTY A):**

*(Full name + Signature)*

**FOR COMPANY (PARTY B):**

*(Full name + Signature)*

-----

-----

**WITNESS ON BEHALF OF PBPO**

*(Full name +signature + stamp)*

-----

---

**Form 04**

**PBPO Province .....**

**No.:** .....<sup>3</sup>

**assignment Contract to Company / Mason Team in Biodigester Programme**

- Pursuant to approved document dated ..... of the Government on approval for the National Biodigester Programme
- Pursuant to the Programme Provincial Guidelines on the National Biodigester Programme

**1. Party A: Provincial Biodigester Programme Office .....**

Address: ..... Telephone:.....

Account: .....

Representative by: ..... Title: Chief of PBPO

**2. Party B: Company / Mason Team<sup>4</sup>.**

Address: ..... Telephone:.....

Representative by: ..... Title: Team Leader

ID number ....., issued on....., by .....

**3. Both Parties agree to participate in construction work of biodigester programme upon the following commitments:**

**Article 1. Scope of work:**

Party A agrees to accept Party B to participate in construction works of biodigester of the Programme.

**Article 2. Obligations**

**Party A:**

- + Organise training course and grant certificate upon the successful completion to Party B with full expenses born by Party A
- + Give full essential technical support and technical documents to Party B
- + Recommend construction job of biodigesters within programme framework to party B

---

<sup>3</sup> Contract Number is in province sequence.

<sup>4</sup> Company or Mason Team is in province sequence

---

**Party B:**

- + Participate all compulsory training courses organised by Party A
- + Proceed construction works for recommended biodigesters based on given programme plan and programme technical specifications and quality standards required by Party A.
- + Warranty plant quality for a duration of 24 months since the acceptance date.
- + Deposit a collateral security for guaranteeing construction works as specified in the Article 3.

**Article 3. Collateral deposit**

- + Collateral security amount of US\$ 10 (ten American dollars only) will be deposited by Party B in PBPO' accounts at the ACLEDA bank to secure Party B's warranty obligation on biodigesters constructed by this party.
- + In case Party B can not perform his warranty obligation on his construction work then Party A has right to release the collateral deposit in order to compensate for approved lost to biodigester owners
- + At least 15 days after the contract's expiry date, Party A has to release the remain collateral deposit and bank interest to Party B in case Party B completed all his job requirements.

**Article 4. Unilateral Termination of construction contract and compensation:**

- + Each party has right to terminate the construction contract unilaterally and can request for compensation when the other party offends contract provisions.
- + The offending party has to compensate all expenses which the other party had paid for the lost, unless otherwise stated.

**Article 5. Complain and dispute settlement:**

All complains and disputes will be considered and settled by both parties based on mutual interest. If both parties can not reach final agreement then the matter will be brought before Civil Court for final.

This contract is made on date... month... year 200... in 2 copies of the same value and become effective since the signing date to date... month... year...

Party (A):

**PBPO Chief**

*(Signature + stamp)*

Party (B):

**Biodigester Mason Team Leader**

*(full name + signature)*

PBPO PROVINCE.....

## BIODIGESTER CONSTRUCTION COMPLETION REPORT

### General

Serial No:.....  
Name of Plant Owner:.....  
Name of Household Head: .....,  
Address: Village.....  
District.....  
Province.....  
No. of family Members sharing the kitchen: .....,  
Size of Plant: 4/6/8/10 cum  
  
Name of Mason Responsible:.....  
Name of Company:.....  
Date of Start of Construction: .....,  
Date of Completion of Construction:.....

### Feeding Materials

No. of Adult Cattle:.....  
No. of Adult Pig:.....  
Total Quantity of Dung Produced:..... kg/day  
Total Quantity of Dung Fed: :..... kg/day  
Toilet constructed: Yes/No  
Latrine Attached to biodigester: Yes/No  
Provision of future attachment: Yes/No

### Location of Plant

Distance from Kitchen:.....  
Distance from Cattle shed/Pig Sty:.....  
Distance from dug well/tube well:.....  
Ground water problem: Yes/No  
Ease in Dung Feeding: Easy/Moderate/Difficult  
Safe from erosion, vandalisms etc.: Yeas/No

Date:.....

### Quality of Construction

Total Quantity of Cement used:.....Bags  
Gas Stoves Brand:..... Installed No:.....  
Gas Lamp Brand:..... Installed No:.....  
Main Gas Valve Brand:.....  
Water Outlet Brand: .....,  
Gas tap Brand:.....  
Type of Dome Gas Pipe:.....  
Type of Gas Pipe:  

- GI 13 mm, Flexible Plastic
- 13 mm, PVC 17 mm,
- Other (specify).....

Length of Pipeline: ..... metre  
Depth of Pipe trench:.....  
Sealing Agent(s): Teflon Tape, .....,  
Quality of plaster inside the digester:  
good/fair/poor  
Quality of plaster coats inside gas holder:  
good/fair/poor  
Thickness of Outlet slab: .....,  
Quality of Outlet slab: good/fair/poor  
Quality of water drain pit: good/fair/poor  
Quality of workmanship in general:  
good/fair/poor  
No of composing pit: 0/1/2  
Total volume of Compost pit: .....,  
Condition of the surrounding: clean/dirty/very  
dirty  
Symmetry of inlet pipe, digester, manhole and  
outlet maintained: Yes/No  
Overall Comments:  
.....

## Measurement of Different Components

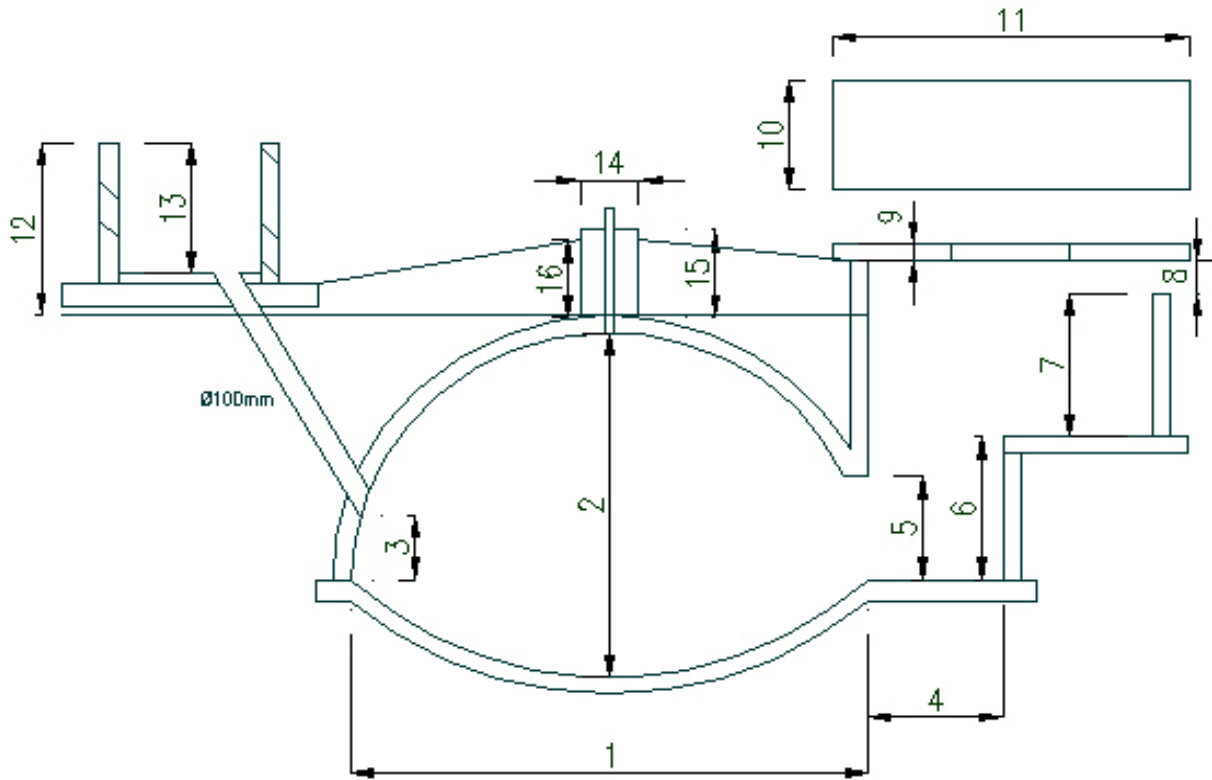

1.	Inner Diameter of digester:	.....	cm
2.	Total inner height of digester:	.....	cm
3.	Height from top of collar to inlet pipe:	.....	cm
4.	Length of manhole floor:	.....	cm
5.	Height of manhole up to top of arch:	.....	cm
6.	Height of manhole up to the floor of outlet:	.....	cm
7.	Height of outlet – the bottom of over flow opening	.....	cm
8.	Height of overflow opening:	.....	cm
9.	Thickness of slab:	.....	cm
10.	Breadth of outlet:	.....	cm
11.	Length of outlet:	.....	cm
12.	Height of inlet from the ground level:	.....	cm
13.	Inner height of the inlet chamber:	.....	cm
14.	Size of turret:	.....	cm
15.	Height of turret:	.....	cm
16.	Height of top filling over dome:	.....	cm

**PBPO PROVINCE.....**

**Form 06**

**NATIONAL BIODIGESTER PROGRAMME  
Biodigester – warranty certificate**

Biodigester size: ..... m<sup>3</sup>;                      Plant code code: .... – .... – .... / .....

Household Head: .....

Address: .....

Date of Acceptance: ..... / ..... / 200 .....

Warranty Performance Organisation: Company Code: .... – .... – ....

Address: ..... Telephone: .....

Team Leader: .....

Warranty period will be 24 months since the acceptance date.

All faults caused from the following reasons will not be guaranteed:

1. Material quality does not meet programme requirement.
2. Operation and maintenance activities are not correct to programme instructions.
3. Changes or repair activities done not by mason team.

For user only:

Date	Trouble	Repair activities	Name of technician (Full name + signature)

**Mason Team Leader**  
(Full name + signature)

PBPO PROVINCE.....

Form 7a

**Quality Control of a Non-filled Biodigester  
 Questionnaire to be filled during the Visit to Under-construction  
 Biodigester**

ID No	Parameters	Responses
1	Sample No	
2	Name of the Installer	
3	Address of the Installer	
4	Name of Mason	
5	Registration no. of Mason	
6	Name of the Biodigester Owner	
7	Name of the Household Head	
8	Name of the Respondent	
9	Relation with Plant Owner	
10	Address: Commune	
11	District	
12	Province	
13	Biodigester Size	4/6/8/10 cum
14	Date of Commencement of the Construction	
15	Date of Completion	
16	If construction time longer than 30 days, reason	
17	One Biodigester per household	Yes/No
18	Use for owner-household only	Yes/No
19	No. of People using the gas	..... persons
20	No. of Cattle	.... Adult, ..... calf, ..... total
21	No of Pig/pig	.... Adult, ..... calf, ..... total
22	Quantity of available cattle dung	..... kg
23	Quantity of feeding expected	..... kg
24	Cattle dung/pig manure being collected for the initial feeding	Yes/No
25	Toilet constructed in the house	Yes/No
26	Toilet attached to the Biodigester	Yes/No
27	Provision for future attachment	Yes/No
	<b>Financing</b>	
28	Total cost of Installation	USD.....
29	Subsidy amount	USD.....
30	Subsidy received	Yes/No
31	Subsidy through	Bank/Company/Mason/other
32	Loan taken	Yes/No
33	If yes, taken from	<b>Bank/MFI/Local money lenders</b>
34	Bank service	Good/satisfactory/poor
35	Duration of loan process	..... days

36	Facilitating/intermediating agency	none/ .....
	<b>Observation</b>	
	<b>Location of the Biodigester</b>	
37	Distance from Kitchen	.....m
38	Distance from cattle shed/pig sty	.....m
39	Distance from the nearest structure	.....m
40	Distance from the nearest tree	.....m
41	Distance from well/water source	.....m
42	Ground water problem	Yes/No
43	Flood/stagnant water problem	Yes/No
	<b>Bricks</b>	
44	Best locally available	Yes/No
45	Shape	Good/fair/bad
46	Sound	Good/fair/bad
47	Drop test	Good/fair/bad
48	<b>Sand</b> – Bottle test	.....% impurity
	<b>Gravel</b>	
49	Cleanliness	Good/fair/bad
50	Maximum size	..... mm
51	Shape	Good/fair/bad
	<b>Cement</b>	
52	Total quantity used/purchased	..... bags of ...kg
53	Brand name	
54	Lumps	Yes/No
	<b>Paint</b>	
55	Total quantity used/purchased	..... litres
56	Type	Acrylic emulsion/.....
57	Brand name	
	<b>MS Reinforcement rod</b>	
58	Diameter	..... mm
59	Quantity purchased	..... kg
	<b>Digester and gas holder</b>	
60	Finishing of floor	Good/fair/bad
61	Diameter of digester	..... cm
62	Height of curved bottom	.....cm
63	Overall height from bottom centre to top of	.....cm/not yet complete

## GUIDELINE ON IMPLEMENTATIONS of PROGRAMME ACTIVITIES IN PROVINCIAL OFFICES

	dome	
64	Height from manhole floor to inlet pipe	.....cm/ not yet complete
65	Height of manhole up to top of arch	.....cm/ not yet complete
66	Height of manhole up to floor of outlet	.....cm/ not yet complete
67	Dome gas pipe in the centre	.....cm/ not yet complete
68	Plastering inside the gas holder (according to the construction manual)	Good/fair/bad/ not yet complete
69	Top filling over dome	Good/fair/bad/ not yet complete
	<b>Outlet</b>	
70	Inner length	.....cm/ not yet complete
71	Inner breadth	.....cm/ not yet complete
72	Height of tank up to the bottom of overflow opening	.....cm/ not yet complete
73	Height and length of overflow opening	.....cm/ not yet complete
74	Accuracy plumb walls	Yes/No/ not yet complete
75	Floor and wall finishing	Good/fair/bad/ not yet complete
76	Floor level difference	.....%/ not yet complete
77	Top of wall difference	.....%/ not yet complete
78	Backfilling against the wall	Good/fair/bad/ not yet complete
79	Thickness of slab	..... cm/ not yet complete
80	Slab as per dimension	Yes/No/ not yet complete
	<b>Inlet</b>	
81	Type	Mixing tank for cattle dung/channel for pig manure
82	Finishing	Good/fair/bad/ not yet complete
82	Height of inlet pit	..... cm/ not yet complete
84	Inlet floor vs. bottom of overflow opening	sufficiently above/just above/below/ not yet complete
85	Type of inlet pipe	PVC/Concrete/Other
86	Inlet pipe position	..... degree in hart-line
87	Easy to insert rod	Yes/No
88	Diameter of inlet pipe	..... cm
	<b>If toilet Attached,</b>	
89	Position of Pan level vs. bottom of overflow opening	sufficiently above/just above/below/ not yet complete
90	Type of inlet pipe	PVC/Concrete/Other
91	Positioning of inlet pipe	..... degree in hart-line
92	Diameter of inlet pipe	..... cm
93	Pipe Provisions for future attachment	Yes/No
94	If not, the reason	

## GUIDELINE ON IMPLEMENTATIONS of PROGRAMME ACTIVITIES IN PROVINCIAL OFFICES

	<b>Appliances</b>	
95	Brand name of dome gas pipe	
96	Quality of dome gas pipe	Good/fair/bad
97	Brand name of main gas valve	DTW/.....
98	Quality of main gas valve	Good/fair/bad
99	Type of gas pipe	PVC/Flexible plastic/GI .....Φ
100	Quality of gas pipe	Good/fair/bad
101	Brand name of water drain	DTW/.....
102	Quality of water drain	Good/fair/bad
103	Brand name of gas tap	DTW/.....
104	Quality of gas tap	Good/fair/bad
105	Brand name of stove	DTW/.....
106	No. of stoves	1/2/3
107	Quality of stove	Good/fair/bad
108	Expected duration of stove-use	..... hour/day
109	Quality of connecting pipe	Good/fair/bad
110	Brand name of lamps	Chinese/.....
111	No. of lamps	1/2/3/4
112	Quality of lamp	Good/fair/bad
113	Expected duration of lamp use	..... hour/day
	<b>Condition of Pipeline</b>	
114	Sealing agent	Good/fair/bad
115	Unnecessary fittings	Yes/No/ not yet complete
116	Pipe buried where possible	Yes/No/ not yet complete
117	Depth of trench	..... cm/ not yet complete
118	Pipe protected against damage	Yes/No/ not yet complete
119	Water drain able to drain condensed water	Yes/No/ not yet complete
120	Drain pit properly maintained	Yes/No/ not yet complete
	<b>Instructions to User</b>	
121	User properly instructed	Yes/No/ not yet
122	If yes, by whom	Mason/supervisor/.....
123	Who was instructed	Male member/Female member
124	Instruction booklet provided	Yes/No/ not yet
125	Remarks, if any	
	Form Filled by (Officer from PBPO)	
	Seconded by (The user)	
	Agreed by (The company/installer/mason)	

**Form 7b**

**Quality Control of an Operational Biodigester  
Questionnaire to be filled for Filled (Operational) Plants**

<b>ID No</b>	<b>Parameters</b>	<b>Responses</b>
1	Sample No	
2	Name of the Installer	
3	Address of the Installer	
4	Name of Mason	
5	Registration no. of Mason	
6	Name of the Biodigester Owner	
7	Name of the Household Head	
8	Name of the Respondent	
9	Relation with Plant Owner	
10	Address: Commune	
11	District	
12	Province	
13	Plant Size	4/6/8/10 cum
14	Date of Commencement of the Construction	
15	Date of Completion	
16	If construction time longer than 30 days, reason	
17	Date of commencement of operation	
18	One plant per household	Yes/No
19	Use for owner-household only	Yes/No
20	No. of People using the gas	..... persons
21	No. of Cattle	.... Adult, ..... calf, ..... total
22	No of Pig/pig	.... Adult, ..... calf, ..... total
23	Quantity of available cattle dung	..... kg/day
24	Quantity of dung/pig manure being fed into the digester	..... kg/day
25	Quantity of water being fed into the digester	..... litre/day
26	Toilet constructed in the house	Yes/No
27	Toilet attached to the Biodigester	Yes/No
28	Provision for future attachment	Yes/No
	<b>Financing</b>	
29	Total cost of Installation	USD.....
30	Subsidy amount	USD.....
31	Subsidy received	Yes/No
32	Subsidy through	Bank/Company/Mason/other

33	Loan taken	Yes/No
34	If yes, taken from	Bank/MFI/Local money lenders
35	Bank service	Good/satisfactory/poor
36	Duration of loan process	..... days
37	Facilitating/intermediating agency	none/ .....
38	Provision of Guarantee and ASS	Yes/No
39	Guarantee card provided	Yes/No
	<b>Observation</b>	
	<b>Location of the plant</b>	
40	Distance from Kitchen	.....m
41	Distance from cattle shed/pig sty	.....m
42	Distance from the nearest structure	.....m
43	Distance from the nearest tree	.....m
44	Distance from well/water source	.....m
45	Ground water problem	Yes/No
46	Flood/stagnant water problem	Yes/No
	<b>Digester and gas holder</b>	
47	Top filling over dome	Good/fair/bad
48	Top filling erosion proof	Yes/No
	<b>Outlet</b>	
49	Backfilling against the wall	Good/fair/bad
50	Condition of slab	..... cm
51	Slab as per dimension	Yes/No
	<b>Inlet</b>	
52	Type	Mixing tank for cattle dung/channel for pig manure
53	Finishing	Good/fair/bad
54	Height of inlet pit	..... cm
55	Inlet floor vs. bottom of overflow opening	sufficiently above/just above/below
56	Type of inlet pipe	PVC/Concrete/Other
57	Inlet pipe position	..... degree in hart-line
58	Easy to insert rod	Yes/No
59	Diameter of inlet pipe	..... cm
	<b>If toilet Attached,</b>	
60	Position of Pan level vs. bottom of overflow opening	sufficiently above/just above/below/ not yet complete

61	Type of inlet pipe	PVC/Concrete/Other
62	Positioning of inlet pipe	..... degree in hart-line
63	Diameter of inlet pipe	..... cm
64	Pipe Provisions for future attachment	Yes/No
	<b>Appliances</b>	
65	Brand name of dome gas pipe	
66	Functioning of dome gas pipe	Good/fair/bad
67	Brand name of main gas valve	DTW/....
68	Functioning of main gas valve	Good/fair/bad
69	Type of gas pipe	PVC/Flexible plastic/GI ..... $\Phi$
70	Functioning of gas pipe	Good/fair/bad
71	Brand name of water drain	DTW/.....
72	Functioning of water drain	Good/fair/bad
73	Brand name of gas tap	DTW/.....
74	Functioning of gas tap(s)	Good/fair/bad
75	Brand name of stove	DTW/.....
76	No. of stoves	1/2/3
77	Functioning of stove	Good/fair/bad
78	Total duration of stove-use	..... hour/day
79	Quality of connecting pipe	Good/fair/bad
80	Brand name of lamps	Chinese/.....
81	No. of lamps	1/2/3/4
82	Functioning of lamp	Good/fair/bad
83	Total duration of lamp use	..... hour/day
	<b>Condition of Pipeline</b>	
84	Sealing agent	Good/fair/bad
85	Unnecessary fittings	Yes/No/ not yet complete
86	Pipe buried where possible	Yes/No/ not yet complete
87	Depth of trench	..... cm/ not yet complete
88	Pipe protected against damage	Yes/No/ not yet complete
89	Water drain able to drain condensed water	Yes/No/ not yet complete
90	Drain pit properly maintained	Yes/No/ not yet complete
91	Gas pressure	cm of water column
92	Time of measurement	Before cooking/..... hours after cooking
	<b>Operation and Maintenance</b>	
93	User properly instructed	Yes/No/ not yet
94	If yes, by whom	

95	Who was instructed	
96	Instruction booklet provided	Yes/No/ not yet
97	Visits from the installer	more than once in a month/once in 2-3 months/ regularly when called/Never
98	Major maintenance carried out	None a. .... b. .... c. .... d. ....
99	Total expenditure on maintenance	Riel...../year
100	Pending urgent maintenance work	None a. .... b. .... c. .... d. ....
101	Overall functional status of biodigester	Functioning well/functioning satisfactorily/functioning partly/not functioning
102	Remarks, if any	
	Form Filled by (Officer from PBPO)	
	Seconded by (The user)	
	Agreed by (The company/installer/mason)	

# Activity report

**Form 8**

Provincial Biodigester Programme Office : .....

Date: Month...../Quarter....., 200.....

Items	Activities	Unit	Plan	Result	Descriptions
<b>A</b>	<b><i>Promotion and Marketing</i></b>				
A.1	Promotion activities				
a	Public Media				
b	Deliver brochures, leaflets, posts				
A.2	Investigate potential customers				
A.3	Promotion activities to customers				
A.4	Registration for Biodigesters				
<b>B</b>	<b><i>Construction and Maintenance</i></b>				
B.1	Construction of biodigester				
B.2	Maintenance				
<b>C</b>	<b><i>Training</i></b>				
C.1	Biodigestertechnician				
C.2	Biodigester mason				
a	Biodigester experienced mason				
b	Biodigester fresh mason				
C.3	Biodigester user				
C.4	Related officers				
<b>D</b>	<b><i>Comprehensive application extension</i></b>				
D.1	Model design				
D.2	Biodigester newsletter				

***Petition:***

.....  
 .....  
 .....

Prepared by  
 (Full name + signature)

Date: ..... month.....200...  
**PBPO CHIEF**  
 (Signature + stamp)

**Form 09**

**LIST OF BIODIGESTER USERS FOR SUBSIDY PAYMENT**

**PBPO:** .....  
**Period:** From ...../...../200... to ...../...../200...

No.	Name	Address			ID No.	Plant code	Date of acceptance
		District	Commune	Village			
1							
2							
3							
4							
5							
6							
7							
8							
9							
10							

Prepared by  
(Full name + signature)

Date: ..... month.....200...  
**PBPO CHIEF**  
(Signature + stamp)

**Form 10**

**National Biodigester Program  
 Biodigester Monitoring Form**

Name of Biodigester Owner	Mr/Mrs.....
Address	Commune: ..... District: ..... Province: .....
Name of user(s) consulted during visit	1. .... 2. ....
Size of Biodigester	4 / 6 / 8 / 10 cum
Visited by	1. .... 2. ....
Date of Visit	.....
Purpose of Visit	1. .... 2. .... 3. ....
Main activities carried out at the site during the visit	1. .... 2. .... 3. ....
Existing problems reported by the user(s), if any	1. .... 2. .... 3. ....
Instruction given to the users	1. .... 2. .... 3. ....
User's level of satisfaction	Fully satisfied/Partly satisfied/Not-satisfied
Reason for not satisfying fully	..... .....
Comments on Overall Condition and functioning of the biodigester	..... ..... .....
Recommendation for follow-up	..... ..... .....

Signature:.....

Date: .....

**Form 11**

**New Mason's Training for Construction of Biodigester  
 Plan of Action for OJT**

Name of Participant	.....
Name of Company/Organisation	..... .....
Date of Commencement of OJT	.....
Name of the Supervisor during OJT	.....
Name and Address of house-owner -1 for OJT	Name:..... Commune: ..... District: ..... Province: ..... Contact Tel No.: .....
Name and Address of House-owner – 2 for OJT	Name:..... Commune: ..... District: ..... Province: ..... Contact Tel No.: .....
Date of Completion of OJT	.....
Assistance envisaged from NBP Office	..... ..... ..... .....

*I hereby agree that I will complete the OJT before ..... (within 60 days from the completion of the theoretical training).*

.....  
 Signature of Participant

.....  
 Date